

Digital Palmcorder® MultiCam™ Camcorder

# Panasonic®

## Operating Instructions

Digital Video Camcorder

Model No. **PV-GS33**

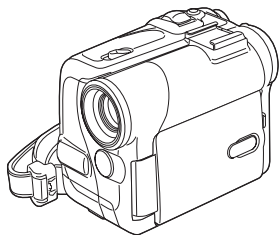

Before attempting to connect, operate or adjust this product, please read these instructions thoroughly.

Spanish Quick Use Guide is included.

Guía para rápida consulta en español está incluida.

Mini **DV**

CERTIFIED **USB**

For USA assistance, please call: 1-800-211-PANA(7262) or, contact us via the web at: <http://www.panasonic.com/contactinfo>

LSQT0833 A

## Things You Should Know

### Thank you for choosing Panasonic!

You have purchased one of the most sophisticated and reliable products on the market today. Used properly, we're sure it will bring you and your family years of enjoyment. Please take time to fill in the information on the right.

The serial number is on the tag located on the underside of your Camcorder. Be sure to **retain this manual** as your convenient Camcorder information source.

Date of Purchase

Dealer Purchased From

Dealer Address

Dealer Phone No.

Model No.

Serial No.

## Safety Precautions

**WARNING: TO PREVENT FIRE OR SHOCK HAZARD,  
DO NOT EXPOSE THIS EQUIPMENT TO RAIN OR MOISTURE.**

Your <sup>Mini</sup> **IN** Camcorder is designed to record and play back in Standard Play (SP) mode and Long Play (LP) mode

It is recommended that only cassette tapes that have been tested and inspected for use in Camcorder with the <sup>Mini</sup> **IN** mark be used.



**CAUTION**  
RISK OF ELECTRIC SHOCK  
DO NOT OPEN



CAUTION: TO REDUCE THE RISK OF ELECTRIC SHOCK,  
DO NOT REMOVE COVER (OR BACK)  
NO USER-SERVICEABLE PARTS INSIDE  
REFER SERVICING TO QUALIFIED SERVICE PERSONNEL



This symbol warns the user that uninsulated voltage within the unit may have sufficient magnitude to cause electric shock.

Therefore, it is dangerous to make any kind of contact with any inside part of this unit.



This symbol alerts the user that important literature concerning the operation and maintenance of this unit has been included. Therefore, it should be read carefully in order to avoid any problems.

### AC Adaptor

- The rating plate is on the underside of the AC Adaptor.

**FCC Note:** This equipment has been tested and found to comply with the limits for a Class B digital device, pursuant to Part 15 of the FCC Rules. These limits are designed to provide reasonable protection against harmful interference in a residential installation. This equipment generates, uses, and can radiate radio frequency energy and, if not installed and used in accordance with the instructions, may cause harmful interference to radio communications. However, there is no guarantee that interference will not occur in a particular installation. If this equipment does cause harmful interference to radio or television reception, which can be determined by turning the equipment off and on, the user is encouraged to try to correct the interference by one or more of the following measures:

- Reorient or relocate the receiving antenna.
- Increase the separation between the equipment and receiver.
- Connect the equipment into an outlet on a circuit different from that to which the receiver is connected.
- Consult the dealer or an experienced radio/TV technician for help.

**FCC Caution:** To assure continued compliance, follow the attached installation instructions and use only shielded interface cables with ferrite core when connecting to computer or peripheral devices. Any changes or modifications not expressly approved by the party responsible for compliance could void the user's authority to operate this equipment.

**Declaration of Conformity**

**Trade Name:** Panasonic  
**Model No.:** PV-GS33  
**Responsible party:** Matsushita Electric Corporation of America  
One Panasonic Way, Secaucus, NJ 07094  
**Support Contact:** Panasonic Consumer Electronics Company  
1-800-211-PANA (7262)

This device complies with Part 15 of the FCC Rules. Operation is subject to the following two conditions: (1) This device may not cause harmful interference, and (2) this device must accept any interference received, including interference that may cause undesired operation.

**CAUTION: TO PREVENT FIRE OR SHOCK HAZARD AND ANNOYING INTERFERENCE, USE THE RECOMMENDED ACCESSORIES ONLY.**

**CAUTION: TO PREVENT ELECTRIC SHOCK, MATCH WIDE BLADE OF PLUG TO WIDE SLOT, FULLY INSERT.**

**CAUTION: DANGER OF EXPLOSION IF BATTERY IS INCORRECTLY REPLACED. REPLACE ONLY WITH THE SAME OR EQUIVALENT TYPE.**

- Since this product gets hot during use, operate it in a well ventilated place; do not install this equipment in a confined space such as a bookcase or similar unit.

**Panasonic** PV-GS33



Tested To Comply  
With FCC Standards

FOR HOME OR OFFICE USE

## **IMPORTANT SAFETY INSTRUCTIONS**

- 1) Read these instructions.
- 2) Keep these instructions.
- 3) Heed all warnings.
- 4) Follow all instructions.
- 5) Do not use this apparatus near water.
- 6) Clean only with dry cloth.
- 7) Do not block any ventilation openings. Install in accordance with the manufacturer's instructions.
- 8) Do not install near any heat sources such as radiators, heat registers, stoves, or other apparatus (including amplifiers) that produce heat.
- 9) Do not defeat the safety purpose of the polarized or grounding-type plug. A polarized plug has two blades with one wider than the other. A grounding type plug has two blades and a third grounding prong. The wide blade or the third prong are provided for your safety. If the provided plug does not fit into your outlet, consult an electrician for replacement of the obsolete outlet.
- 10) Protect the power cord from being walked on or pinched particularly at plugs, convenience receptacles, and the point where they exit from the apparatus.
- 11) Only use attachments/accessories specified by the manufacturer.
- 12) Use only with the cart, stand, tripod, bracket, or the table specified by the manufacturer, or sold with the apparatus. When a cart is used, use caution when moving the cart/apparatus combination to avoid injury from tip-over.
- 13) Unplug this apparatus during lightning storms or when it will be left unused for long periods of time.
- 14) Refer all servicing to qualified service personnel. Servicing is required when the apparatus has been damaged in any way, such as when the power-supply cord or plug is damaged, liquid has been spilled or objects have fallen into the apparatus, the apparatus has been exposed to rain or moisture, does not operate normally, or has been dropped.



## Precautions

### USE & LOCATION

#### WARNING

- **TO AVOID SHOCK HAZARD ...** Your Camcorder and power supply should not be exposed to rain or moisture. Do not connect the power supply or operate your Camcorder if it gets wet. Your Camcorder has been designed for outdoor use, however it is not designed to sustain direct exposure to water, rain, sleet, snow, sand, dust, or a direct splashing from a pool or even a cup of coffee. This action could permanently damage the internal parts of your Camcorder. Do not attempt to disassemble this unit. There are no user serviceable parts inside. Unplug your Camcorder from the power supply before cleaning.

#### CAUTION

- **DO NOT AIM YOUR CAMCORDER AT THE SUN OR OTHER BRIGHT OBJECTS**
- **DO NOT LEAVE THE CAMCORDER WITH THE EVF AIMED DIRECTLY AT THE SUN AS THIS MAY CAUSE DAMAGE TO THE INTERNAL PARTS OF THE EVF**
- **DO NOT EXPOSE YOUR CAMCORDER TO EXTENDED HIGH TEMPERATURE ...** Such as, in direct sunlight, inside a closed car, next to a heater, etc... This action could permanently damage the internal parts of your Camcorder.

- **AVOID SUDDEN CHANGES IN TEMPERATURE ...** If the unit is suddenly moved from a cold place to a warm place, moisture may form on the tape and inside the unit.
- **DO NOT LEAVE YOUR CAMCORDER OR THE POWER SUPPLY TURNED ON WHEN NOT IN USE.**
- **STORAGE OF YOUR CAMCORDER ...** Store and handle your Camcorder in a manner that will not subject it to unnecessary movement (avoid shaking and striking). Your Camcorder contains a sensitive pick-up device which could be damaged by improper handling or storage.

### CARE

- **TO CLEAN YOUR Camcorder ...** Do not use strong or abrasive detergents when cleaning your Camcorder body.
- **TO PROTECT THE LENS ...** Do not touch the surface of the lens with your hand. Use a commercial Camcorder lens solution and lens paper when cleaning the lens. Improper cleaning can scratch the lens coating.
- **TO PROTECT THE FINISH OF YOUR CAMCORDER ...** Before handling your Camcorder, make sure your hands and face are free from any chemical products, such as suntan lotion, as it may damage the finish.

Apparatus Claims of U.S. Patent Nos. 4,631,603, 4,577,216, and 4,819,098, licensed for limited viewing.

This product incorporates copyright protection technology that is protected by method claims of certain U.S. patents and other intellectual property rights owned by Macrovision Corporation and other rights owners. Use of this copyright protection technology must be authorized by Macrovision Corporation, and is intended for home and other limited viewing uses only unless otherwise authorized by Macrovision Corporation. Reverse engineering or disassembly is prohibited.

### U.S.A. CONSUMERS: ATTENTION:



A lithium ion/polymer battery that is recyclable powers the product you have purchased. Please call 1-800-8-BATTERY for information on how to recycle this battery.

---

Before opening the CD-ROM package (optional), please read the following.

## ***End User License Agreement (for USB Driver, WebCam Driver and DV STUDIO)***

You ("Licensee") are granted a license for the Software defined in this End User Software Agreement ("Agreement") on condition that you agree to the terms and conditions of this Agreement. If Licensee does not agree to the terms and conditions of this Agreement, promptly return the Software to Matsushita Electric Industrial Co., Ltd. ("Matsushita"), its distributors or dealers from which you made the purchase.

### **Article 1 License**

Licensee is granted the right to use the software, including the information recorded or described on the CD-ROM, instruction manuals, and any other media provided to Licensee (collectively "Software"), but all applicable rights to patents, copyrights, trademarks and trade secrets in the Software are not transferred to Licensee.

### **Article 2 Use by a Third Party**

Licensee may not use, copy, modify, transfer or allow any third party, whether free of charge or not, to use, copy or modify the Software, except as expressly provided for in this Agreement.

### **Article 3 Restrictions on Copying the Software**

Licensee may make a single copy of the Software in whole or in part solely for back-up purpose.

### **Article 4 Computer**

Licensee may only use the Software on a single computer at a single location.

### **Article 5 Reverse Engineering, Decompiling or Disassembly**

Licensee may not reverse engineer, decompile, or disassemble the Software, except to the extent either of them is permitted under law or regulation of the country where Licensee resides. Matsushita, or its distributors or dealers will not be responsible for any defects in the Software or damage to Licensee caused by Licensee's reverse engineering, decompiling, or disassembly of the Software.

### **Article 6 Limitation of Liability**

The Software is provided "AS-IS" without warranty of any kind, either expressed or implied, including, but not limited to, warranties of non-infringement, merchantability and/or fitness for a particular purpose. Further, Matsushita does not warrant that the operation of the Software will be uninterrupted or error free. Matsushita or any of its distributors or dealers will not be liable for any damage suffered by Licensee arising from or in connection with Licensee's use of the Software.

### **Article 7 Export Control**

Licensee agrees not to export or re-export to any country the Software in any form without the appropriate export licenses under regulations of the country where Licensee resides, if necessary.

### **Article 8 Termination of License**

The right granted to Licensee hereunder will be automatically terminated if Licensee violates any of the terms and conditions of this Agreement. Upon such automatic termination, Licensee must destroy the Software and related documentation together with all the copies thereof at Licensee's own expense.

## Contents

### Before Use

|   |    |
|---|----|
| Quick Guide.....                                | 8  |
| Standard Accessories.....                       | 10 |
| Controls and Components.....                    | 10 |
| The Remote Controller.....                      | 13 |
| Power Supply.....                               | 14 |
| Charging Time and Available Recording Time..... | 14 |
| The One-touch Free Style Grip Belt.....         | 15 |
| Attaching the Lens Cap.....                     | 15 |
| Attaching the Shoulder Strap.....               | 16 |
| Inserting a Cassette.....                       | 16 |
| Turning on the Camcorder.....                   | 16 |
| Selecting Modes.....                            | 16 |
| Using the Viewfinder/LCD Monitor.....           | 17 |
| Using the Menu Screen.....                      | 18 |
| List of Menus.....                              | 18 |
| Setting Date and Time.....                      | 20 |
| Internal Lithium Battery Recharge.....          | 20 |
| LP Mode.....                                    | 20 |
| Audio Recording Mode.....                       | 20 |

### Recording Mode

|                                       |    |
|---------------------------------------|----|
| About Recording.....                  | 21 |
| Recording on a Tape.....              | 21 |
| Photoshot.....                        | 22 |
| Quick Start.....                      | 23 |
| Self-timer Recording.....             | 23 |
| Zoom In/Out Functions.....            | 23 |
| Digital Zoom Function.....            | 24 |
| Image Stabilizer Function.....        | 24 |
| Fade In/Out Functions.....            | 25 |
| Backlight Compensation Function.....  | 25 |
| MagicPix Functions.....               | 26 |
| Soft Skin Function.....               | 26 |
| Wind Noise Reduction Function.....    | 26 |
| Cinema Function.....                  | 27 |
| Recording in Special Situations.....  | 27 |
| Recording in Natural Colors.....      | 27 |
| Adjusting White Balance Manually..... | 28 |
| Manual Shutter Speed Adjustment.....  | 29 |
| Manual Iris Adjustment.....           | 29 |
| Manual Focus Adjustment.....          | 29 |
| Digital Effect Functions.....         | 30 |

### Playback Mode

|  |    |
|--|----|
| Playing Back a Tape.....                   | 32 |
| Finding a Scene You Want to Play Back..... | 32 |
| Slow Motion Playback.....                  | 33 |
| Still Playback/Still Advance Playback..... | 33 |
| Index Search Functions.....                | 34 |
| Playback Zoom Function.....                | 34 |
| Playback Digital Effect Functions.....     | 35 |
| Playing Back on Your TV.....               | 36 |

### Editing Mode

|  |    |
|--|----|
| Audio Dubbing.....                           | 37 |
| Copying on an S-VHS (or a VHS) Cassette..... | 37 |
| Using the DV Cable for Recording.....        | 38 |
| PC Connection With DV Interface Cable.....   | 38 |

### With a PC (optional)

|   |    |
|---|----|
| Using the Software with a Computer.....                   | 39 |
| Using USB Driver.....                                     | 39 |
| Using as a Web Camera.....                                | 40 |
| Using the DV STUDIO 3.1E-SE (Optional Software).....      | 43 |
| If you no longer need Software or Driver (Uninstall)..... | 44 |
| Notes.....  | 44 |

### Others

|   |    |
|---|----|
| Indications.....  | 46 |
| Initializing the Modes.....                                       | 47 |
| Warning/Alarm Indications.....                                    | 47 |
| Notes and Hints.....  | 47 |
| Cautions for Use.....   | 51 |
| Before Requesting Service (Problems and Solutions).....           | 55 |
| Explanation of Terms.....   | 56 |
| Specifications.....   | 58 |
| Camcorder Accessory System.....                                   | 59 |
| Camcorder Accessory Order Form.....                               | 60 |
| Request for Service Notice.....                                   | 61 |
| Limited Warranty.....   | 62 |
| Customer Services Directory.....                                  | 63 |
| Index.....  | 64 |
| Spanish Quick Use Guide/<br>Guía española para el uso rápido..... | 65 |

## Quick Guide

- 1 Attach the Battery to the AC Adaptor and charge it.

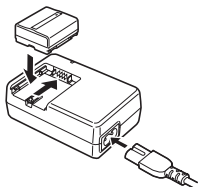

- Before use, fully charge the Battery.
- Since the Battery will not be charged when the DC Cable is connected to the AC Adaptor, disconnect it from the AC Adaptor.
- The [CHARGE] Lamp lights up, and charging starts.
- When the [CHARGE] Lamp goes off, charging is completed.

- 2 Attach the charged Battery to the Camcorder.

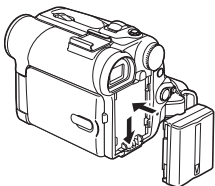

### Inserting a Cassette

- 1 Slide the [OPEN/EJECT] Lever toward the front and pull down to open the Cassette Compartment Cover.
- 2 Insert a Cassette.

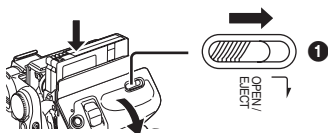

- 3 Close the Cassette Holder by pressing the [PUSH] mark.
- 4 Close the Cassette Compartment Cover.

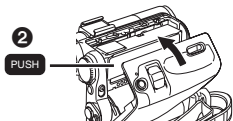

### Recording on a Tape

- 1 Set the [OFF/ON] Switch to [ON].
  - The [POWER] Lamp lights up.

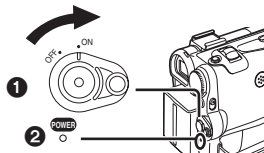

- 2 Set the Mode Dial to Tape Recording Mode.

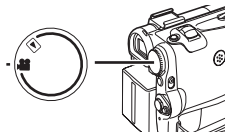

- 3 Press the Recording Start/Stop Button.
  - Recording starts.

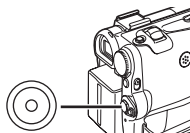

- 4 Press the Recording Start/Stop Button again to pause the recording.

### Recording a Still Picture (Photoshot)

- 1 Set the Mode Dial to Tape Recording Mode.

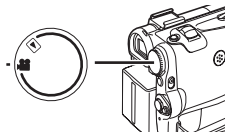

- 2 Press the [PHOTO SHOT] Button in the Recording Pause Mode.

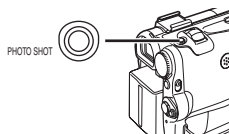



## ■ Playing Back a Tape

1 Set the [OFF/ON] Switch ① to [ON].

- The [POWER] Lamp ② lights up.

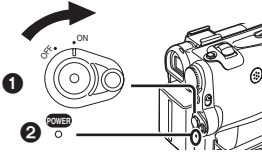

2 Set the Mode Dial to Tape Playback Mode.

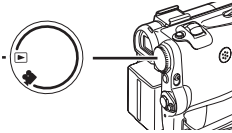

3 Press the [◀◀] Button to rewind the tape.

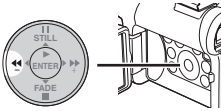

4 Press the [▶] Button to start playback.

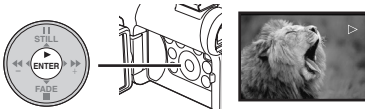

5 Press the [■] Button to stop playback.



## Before Use

### Standard Accessories

Illustrated are accessories supplied with the Camcorder.

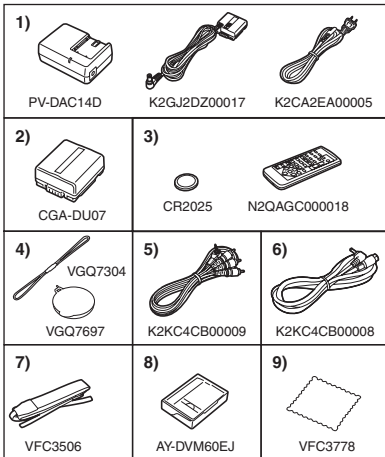

#### 1) AC Adaptor, DC Cable and AC Cable -14-

#### CAUTION:

This unit will operate on 110/120/220/240 V AC. An AC plug adaptor may be required for voltages other than 120 V AC. Please contact either a local or foreign electrical parts distributor for assistance in selecting an alternate AC plug. We recommend using the accessory power plug adaptor (VJSS0070) in an area which has special AC outlets.

- 2) Battery Pack -14-
- 3) Remote Controller and Button-Type Battery -12-
- 4) Lens Cap and Lens Cap Cord -15-
- 5) AV Cable -36-
- 6) S-Video Cable -36-
- 7) Shoulder Strap -16-
- 8) DV cassette
- 9) Cleaning Cloth

## Controls and Components

### Camcorder

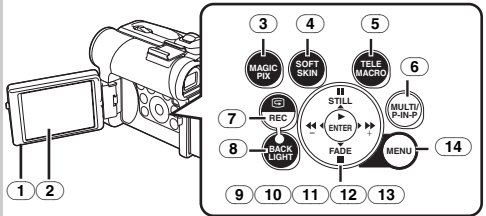

- 1) LCD Monitor Open Knob [OPEN ▼] -17-
- 2) LCD Monitor -17-, -54-

Due to limitations in LCD production technology, there may be some tiny bright or dark spots on the LCD Monitor screen. However, this is not a malfunction and does not affect the recorded picture.

- 3) MagicPix Button [MAGICPIX] -26-
- 4) Soft Skin Button [SOFT SKIN] -26-
- 5) Tele Macro Button [TELE MACRO] -24-
- 6) Multi Button [MULTI] -30-
- Picture-in-Picture Button [P-IN-P] -31-
- 7) Recording Check Button [RECORD] -21-
- 8) Recording Button [REC] -38-
- 9) Backlight Button [BACK LIGHT] -25-
- Pause Button [II] -33-
- Still Button [STILL] -22-
- 10) Fast Forward/Cue Button [▶▶] -32-
- 11) Play Button [▶] -32-
- Enter Button [ENTER] -18-
- 12) Stop Button [■] -32-
- Fade Button [FADE] -25-
- 13) Rewind/Review Button [◀◀] -32-
- 14) Menu Button [MENU] -18-

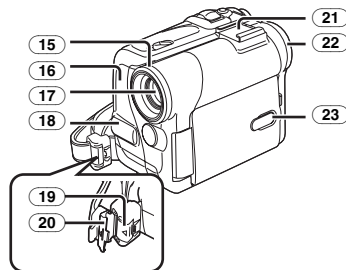

- 15) Lens Hood -54-
- 16) Recording Lamp -21-
- 17) Lens
- 18) Microphone (built-in, stereo) -24-, -26-
- 19) Lock Button -15-
- 20) Lock Cover -15-
- 21) Accessory Shoe

- 22 **Eyecup**
- 23 **Power LCD Button [POWER LCD] -17-  
Power LCD Lamp -17-**

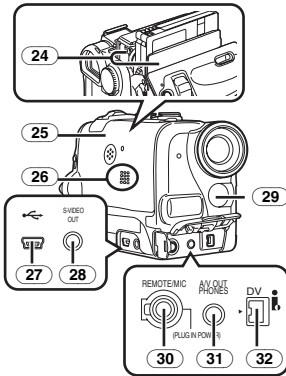

- 24 **Cassette Holder**
- 25 **Cassette Compartment Cover -16-**
- 26 **Speaker -32-**
- 27 **USB Jack [←] -41-**
- 28 **S-Video Output Jack [S-VIDEO OUT] -36-**
- 29 **White Balance Sensor -28-  
Remote Control Sensor -13-**
- 30 **Jack for Magic Wire Remote Control with  
Narration Mic (optional) [REMOTE] -22-  
Microphone Jack [MIC]**

- When connecting an external microphone or audio equipment to this jack, the built-in microphone does not operate.
- When connecting the Magic Wire Remote Control with Narration Mic (optional) to this jack and the [TALK] Button is pressed, the built-in microphone does not operate. (-22-)
- When connecting the pin plug of the Magic Wire Remote Control with Narration Mic (optional) to this jack, plug it in as far as it goes.
- A compatible plug-in powered microphone can be used. Please consult your dealer for more information.
- The microphone may make noises depending on the type used. In this case, we recommend using the battery with the Camcorder to reduce noises instead of the AC adaptor.

- 31 **Audio-Video Output Jack [A/V OUT] -36-  
Headphone Jack [PHONES]**

- Connecting an AV Cable to this jack activates the Camcorder's built-in speaker, but connecting a headphone, etc. deactivates it.
- When connecting the pin plug of the AV Cable to this jack, plug it in as far as it goes.

- When using headphones, set [AV JACK] of the [INITIAL] sub-menu to [OUT/PHONES]. If you set [AV JACK] to [OUT], you may hear noises on the right.

- 32 **DV Terminal [DV] -38-  
•Connect this to the digital video equipment.**

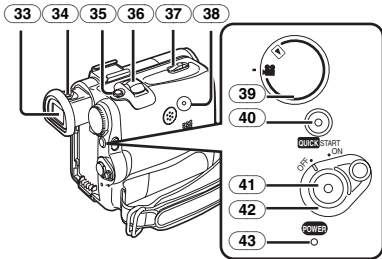

- 33 **Viewfinder -17-, -54-**

Due to limitations in LCD production technology, there may be some tiny bright or dark spots on the Viewfinder screen. However, this is not a malfunction and does not affect the recorded picture.

- 34 **Eyepiece Corrector Knob -17-**
- 35 **Photoshot Button [PHOTO SHOT] -23-**
- 36 **Zoom Lever [W/T], [-VOL/JOG+] -23-, -32-**
- 37 **Cassette Eject Lever [OPEN/EJECT] -16-**
- 38 **Reset Button [RESET] -47-**
- 39 **Mode Dial -16-**
- 40 **Quick Start Recording Button  
[QUICK START] -23-  
Quick Start Recording Lamp -23-**
- 41 **Recording Start/Stop Button -21-**
- 42 **Power Switch [OFF/ON] -16-, -21-, -51-**
- 43 **[POWER] Lamp -16-, -21-, -32-**

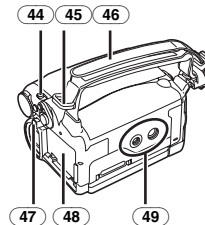

- 44 **Mode Selector Switch  
[AUTO/MANUAL/FOCUS] -21-, -27-, -29-**
- 45 **Shoulder Strap Holders -16-**
- 46 **Grip Belt (One-touch Free Style Grip Belt)  
-15-**
- 47 **Battery Eject Button [PUSH BATT] -14-**
- 48 **Battery Holder**
- 49 **Tripod Receptacle  
•Used for mounting the Camcorder on an  
optional tripod.**

## Remote Controller

Using the wireless Remote Controller that is supplied with the Camcorder, most of the Camcorder functions can be operated from a distance.

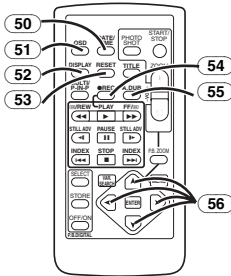

- 50 Date/Time Button [DATE/TIME] -47-
- 51 Indication Output Button [OSD] -36-
- 52 Display Button [DISPLAY] -47-
- 53 Reset Button [RESET] -57-
- 54 Recording Button [●REC] -38-
- 55 Audio Dubbing Button [A.DUB] -37-
- 56 Cursor Buttons for Variable Speed Search Function [▲, ▼] -33-  
Direction Buttons for Playback Zoom Function [▲, ◀, ▶, ▼] -35-

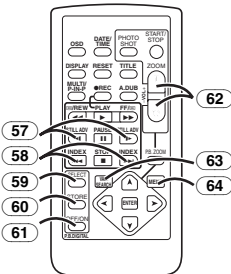

- 57 Slow Motion/Still Advance Buttons [◀I, I▶] (◀I: Reverse, I▶: Forward) -33-
- 58 Index Search Buttons [◀◀, ▶▶] (◀◀: Reverse, ▶▶: Forward) -34-
- 59 Selection Button [SELECT] -35-
- 60 Store Button [STORE] -35-
- 61 Off/On Button [OFF/ON] -35-
- 62 Zoom/Volume Button [ZOOM/VOL] -23-, -32-, -35-
- 63 Variable Speed Search Button [VAR. SEARCH] -33-
- 64 Menu Button [MENU] -18-

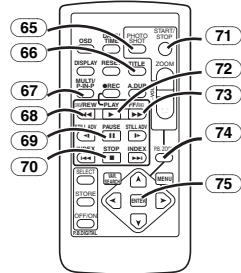

- 65 Photoshot Button [PHOTO SHOT] -23-
- 66 Title Button [TITLE]
  - This Camcorder cannot be operated with this button.
- 67 Multi-Picture/Picture-in-Picture Button [MULTI/P-IN-P] -30-
- 68 Rewind/Review Button [◀◀] -32-
- 69 Pause Button [II] -33-
- 70 Stop Button [■] -32-
- 71 Recording Start/Stop Button [START/STOP] -21-
- 72 Play Button [▶] -33-
- 73 Fast-forward/Cue Button [▶▶] -32-
- 74 Playback Zoom Button [P.B. ZOOM] -34-
- 75 Enter Button [ENTER] -18-

## Magic Wire Remote Control with Narration Mic (optional)

**Magic Wire Remote Control with Narration Mic is not included in this Model. If you wish to order, please refer to the page -59-.**

This controller allows the scene to be shot from various angles, high to low, and is also convenient when a Tripod is used. When the controller is not in use, attach the clip to the Grip Belt for convenience.

This controller makes it easier for left-handed users to use the Camcorder.

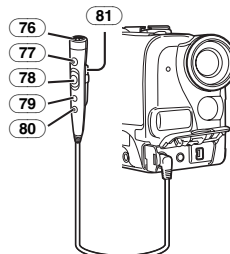

- 76 Microphone [MIC] -22-
- 77 Recording Start/Stop Button [REC]
- 78 Zoom Lever [W/T]
  - Zoom speed changes in 2 stages.
- 79 Photoshot Button [PHOTO SHOT]
- 80 Microphone Switch Button [TALK] -22-

- When the Magic Wire Remote Control with Narration Mic is connected to [REMOTE] Jack and the [TALK] Button is pressed, the narration microphone is activated and the built-in microphone on the Camcorder is deactivated.

**81 Clip**

- **Insert the plug securely into the [REMOTE] Jack as far as it will go. A loose connection will affect normal operation.**

## The Remote Controller

### Inserting a Button-type Battery

Before using the Remote Controller, insert the supplied button-type battery.

- 1 While pressing the Lock Button **1**, pull out the Battery Holder.

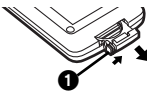

- 2 Insert the button-type battery with the (+) marking facing upwards.



- 3 Insert the Battery Holder into the Remote Controller.

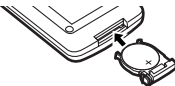

- When the button-type battery is exhausted, replace it with a new CR2025 battery. (A battery is normally expected to last about 1 year. However, it depends on operation frequency.)
- Make sure to match the poles correctly when inserting the battery.

### Warning

**Danger of explosion if battery is incorrectly replaced.**

**Replace only with the same or equivalent type recommended by the equipment manufacturer. Discard used batteries according to manufacturer's instructions. Risk of fire, explosion and burns. Do not recharge, disassemble, heat above 212°F (100°C) or incinerate. Keep the Button-Type battery out of the reach of children. Never put Button-Type battery in mouth. If swallowed, call your doctor.**

Replace battery with Panasonic PART NO. CR2025 only. Use of another battery may present a risk of fire or explosion. Caution: Battery may explode if mistreated. Dispose of used battery promptly. Keep away from children. Do not recharge, disassemble or dispose of in fire.

### Using the Remote Controller

- 1 Direct the Remote Controller at the Remote Control Sensor **29** of the Camcorder and press an appropriate button.

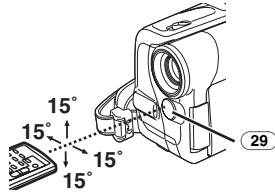

- Distance from the Camcorder: Within approximately 15 feet (5 meters)
- Angle: Approximately 15° in the vertical and horizontal directions from the central axis
- The above operating ranges are for indoor use. Outdoors or under strong light, the Camcorder may not operate properly even within the above ranges.
- Within a 3 feet (1 meter) range, you can also use the Remote Controller on the LCD Monitor side of the Camcorder.

### Selecting Remote Controller Modes

When 2 Camcorders are used simultaneously, they can be operated individually by selecting different Remote Controller Modes.

- If the Remote Controller Mode of the Camcorder and that of the Remote Controller do not match, [REMOTE] Indication is displayed.

### Setup on the Camcorder:

Set [REMOTE] on the [INITIAL] Sub-Menu to the desired Remote Controller Mode. (-19-)

### Setup on the Remote Controller:

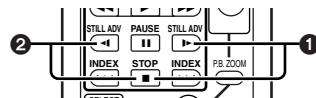

- [VCR1]: Press the [▶] Button and [■] Button simultaneously. **1**
- [VCR2]: Press the [◀] Button and [■] Button simultaneously. **2**

- When the battery in the Remote Controller is replaced, the mode is automatically reset to [VCR1] Mode.

## Power Supply

### Using the AC Adaptor

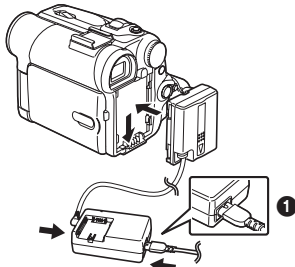

- 1 Connect the DC Cable to the Camcorder.
- 2 Connect the DC Cable to the AC Adaptor.
- 3 Connect the AC Cable to the AC Adaptor and the AC Jack.

- The AC Cable's outlet plug does not fit entirely into the AC Adaptor jack. A gap will remain as shown ❶.
- Before connecting or disconnecting the power supply, set the [OFF/ON] Switch on the Camcorder to [OFF] and make sure that [POWER] Lamp is not lit.

### Using the Battery

Before use, fully charge the Battery.

- We recommend using a Panasonic Battery.
- We cannot guarantee the quality of this Camcorder when batteries from other companies are used.

- 1 Attach the Battery to the AC Adaptor and charge it.

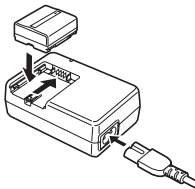

- Since the Battery will not be charged when the DC Cable is connected to the AC Adaptor, disconnect it from the AC Adaptor.
  - The [CHARGE] Lamp lights up, and charging starts.
  - When the [CHARGE] Lamp goes off, charging is completed.
  - When the battery is completely discharged, the [CHARGE] lamp blinks at first, but the battery is charged normally. When the temperature of the battery is too high or low, the [CHARGE] lamp blinks and the charging time becomes longer than usual.
- 2 Attach the charged Battery to the Camcorder.

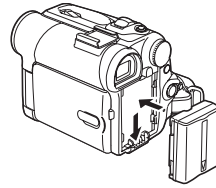

### Disconnecting the Power Source

Set the [OFF/ON] Switch (42) to [OFF] and, while pressing the [PUSH BATT] Button (47), slide the Battery or DC Cable upward to disconnect it.

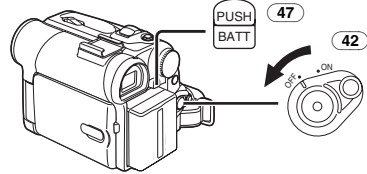

- For other notes concerning this item, see -47-.

### Charging Time and Available Recording Time

|          |     |                     |
|----------|-----|---------------------|
| CGA-DU07 | (A) | 1h30min.            |
|          | (B) | 2h15min. (1h50min.) |
| CGA-DU14 | (A) | 2h45min.            |
|          | (B) | 4h30min. (3h40min.) |
| CGA-DU21 | (A) | 3h55min.            |
|          | (B) | 6h45min. (5h30min.) |

(A) Charging Time

(B) Maximum Continuous Recording Time

- "1h30min." indicates 1 hour and 30 minutes.
- Battery CGA-DU07 is supplied.
- The times shown in the table are approximate times. The numbers indicate the recording time when the Viewfinder is used. The numbers in parentheses indicate the recording time when the LCD Monitor is used. In actual use, the available recording time may be shorter.
- The times shown in the table are for continuous recording at a temperature of 68°F (25°C) and humidity of 60%. If the Battery is charged at a higher or lower temperature, the charging time may be longer.
- In the following cases, the available recording time becomes shorter.
  - You use the Viewfinder and LCD Monitor simultaneously when using the 0 Lux MagicPix function, rotating the LCD Monitor forward to record yourself.
  - When you set [EVF ON/AUTO] to [ON].
  - When you use the Camcorder while lighting the LCD Monitor up by pressing the [POWER LCD] Button.

## The One-touch Free Style Grip Belt

### To Use as a Grip Belt

Adjust the length of the Grip Belt to the size of your hand.

#### 1 Detach the end of the Grip Belt.



#### 2 Adjust the length of the Grip Belt to the size of your hand.



#### 3 Reattach the Grip Belt.

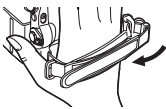

### To Use as a Hand Strap

Using the Grip Belt as the hand strap makes it easier to handle and carry a Camcorder. It is more convenient to use with the Magic Wire Remote Control with Narration Mic (optional).



#### 1 Open the Lock Cover (20) by holding the tabs on both sides (1), press the Lock Button (19) and detach the Grip Belt.

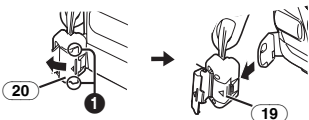

#### 2 Detach the end of the Grip Belt.

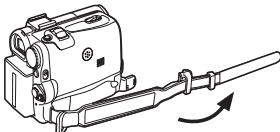

#### 3 Slide (A) in the direction of the arrow and reattach the Grip Belt.

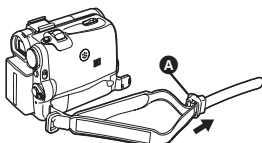

#### 4 Attach the Grip Belt around your wrist.

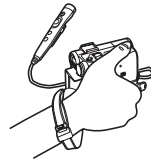

- When returning the Grip Belt to the Grip Belt Attachment, press the Lock Cover (2) to ensure that it is securely locked.

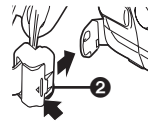

## Attaching the Lens Cap

To protect the Lens surface, attach the Lens Cap.

#### 1 Pass one end of the Lens Cap Cord through the attached eye on the Lens Cap. Then pass the other end through the loop made by itself and pull tight.

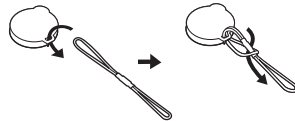

#### 2 Pass the end of the Lens Cap Cord through the hole in the Grip Belt Attachment and the Lens Cap through the Lens Cap Cord.

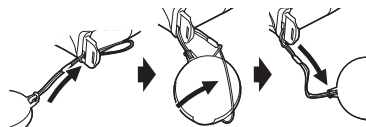

- The removed Lens Cap can be hooked onto the Grip Belt. (It is not possible when using as a hand strap.)
- When you are not recording, be sure to cover the Lens with the Lens Cap for protection.

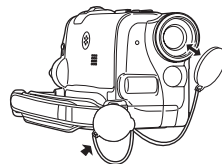

## Attaching the Shoulder Strap

We recommend that you attach the Shoulder Strap before going out to avoid dropping the Camcorder.

- 1 Pull the end of the Shoulder Strap through the Shoulder Strap Holder (45) on the Camcorder.

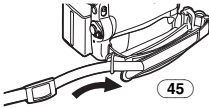

- 2 Fold the end of the Shoulder Strap, run it through the Shoulder Strap Length Adjuster, and pull it.

- Pull it out more than 1 inch (2 cm) (1) from the Shoulder Strap Length Adjuster so that it cannot slip off.

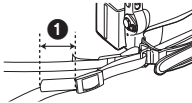

- Attach the other end of the Shoulder Strap to the other Shoulder Strap Holder in the same way.

## Inserting a Cassette

- 1 Slide the [OPEN/EJECT] Lever (37) toward the front and pull down to open the Cassette Compartment Cover.

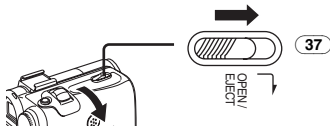

- 2 Insert a Cassette.

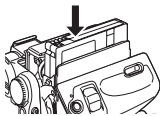

- 3 Close the Cassette Holder by pressing the [PUSH] mark (1).

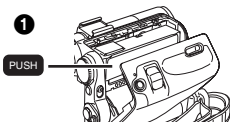

- 4 Close the Cassette Compartment Cover.

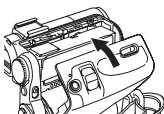

## Accidental Erasure Prevention

Opening the accidental erasure prevention slider

- 1 on the cassette (by sliding it to the [SAVE] arrow direction) prevents recording. To enable recording, close the accidental erasure prevention slider (by sliding it to the [REC] arrow direction).

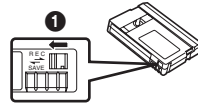

- For other notes concerning this item, see -47-.

## Turning on the Camcorder

When the Camcorder is turned on with the Lens Cap on, the Automatic White Balance Adjustment may not function properly. Please turn on the Camcorder after removing the Lens Cap.

### How to Turn on the Power

- 1 Set the [OFF/ON] Switch (42) to [ON] while pressing the button (1).

- The [POWER] Lamp (43) lights up.

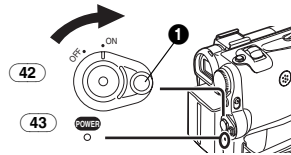

### How to Turn off the Power

- 1 Set the [OFF/ON] Switch (42) to [OFF] while pressing the button (1).

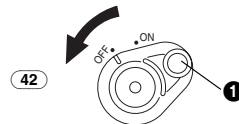

## Selecting Modes

You can choose a desired mode by rotating the Mode Dial.

- 1 Rotate the Mode Dial (39).

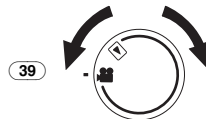

### :Tape Recording Mode

Use this mode when recording pictures on a tape.

### :Tape Playback Mode

Use this mode when playing back the recorded scene on a tape.



## Using the Viewfinder/LCD Monitor

### Using the Viewfinder

Before using the Viewfinder, adjust the field of view so that the displays inside the Viewfinder become clear and easy to read.

#### 1 Pull the Viewfinder.

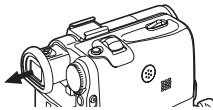

#### 2 Adjust by turning the Eyepiece Corrector Knob (34).

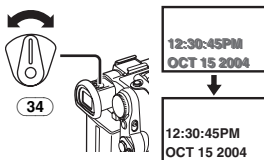

### To Use the Viewfinder at the Same Time as the LCD Monitor

Set [LCD/EVF] >> [EVF ON/AUTO] >> [ON].

- The Viewfinder does not turn off even if the LCD Monitor is opened.
- When you turn the Camcorder off, this setting is cancelled.

### Using the LCD Monitor

With the LCD Monitor open, you can also record the picture while watching it.

#### 1 Using your Thumb on the [OPEN▼] Knob

① and pull the LCD Monitor ② out in the direction of the arrow.

- The Viewfinder is now deactivated.
- The LCD Monitor can be opened a maximum of 120°. If you open the LCD monitor by 120°, it becomes convenient to operate menus or to play back pictures.

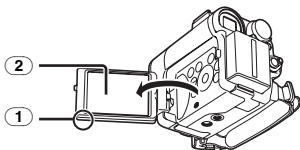

#### 2 Adjust the LCD Monitor angle according to the desired recording angle.

- The LCD Monitor can rotate a maximum of 180° ① from the vertical position upwards and a maximum of 90° ② to the downward direction. Forcefully rotating the LCD Monitor beyond these ranges will damage the Camcorder. You cannot rotate the LCD Monitor when it is opened to an angle of 120°. Therefore, do not rotate it forcibly.

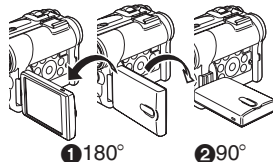

### Closing the LCD Monitor

Push the LCD Monitor until it is securely locked.

### Adjusting Brightness and Color Level

When [LCD/EVF SET] on the [LCD/EVF] Sub-Menu is set to [YES], the following items are displayed.

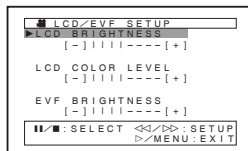

#### LCD Brightness [LCD BRIGHTNESS]

Adjusts the brightness of the image on the LCD screen.

#### LCD Color Level [LCD COLOR LEVEL]

Adjusts the color saturation of the image on the LCD screen.

#### Brightness of the Viewfinder

#### [EVF BRIGHTNESS]

Adjusts the brightness of the image in the Viewfinder.

#### To Adjust

Press the [II/III] Button and select the item to be adjusted, and then press the [◀/▶] Button to raise or lower the number of vertical bars in the Bar Indication.

- More vertical bars indicates stronger brightness or color saturation.

#### To Increase the Brightness of the Entire LCD Monitor

Press the [POWER LCD] Button (23).

When you press [POWER LCD] button, the LCD monitor becomes about twice as bright as usual.

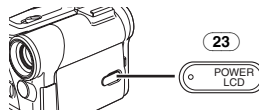

- The [POWER LCD] Lamp (23) lights up.
- When turning the power on while using AC Adaptor, [POWER LCD] function is automatically effective.

#### To Resume Normal Brightness

Press the [POWER LCD] Button again.

- These adjustments do not affect the recorded images.

- For other notes concerning this item, see -54-.

## Using the Menu Screen

To facilitate the selection of a desired function or setup, this Camcorder displays various function setups on Menus.

- When operating the menu with the Viewfinder, set [LCD/EVF] >> [EVF ON/AUTO] >> [ON] or rotate the LCD monitor by 180°.

### 1 Press the [MENU] Button (14).

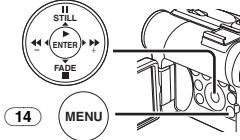

- The Menu corresponding to the Mode selected by using the Mode Dial (39) is displayed.

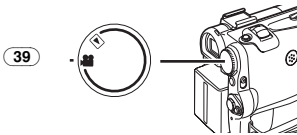

### 2 Press the [II/III] Button to select a desired Sub-Menu.

- Press the [II/III] Button to display the highlighted item.

### 3 Press the [▶▶] Button to display the selected Sub-Menu.

### 4 Press the [II/III] Button to select the item.

### 5 Press the [▶▶] Button to display the selected item.

### 6 Press the [II/III] Button to select the desired mode and press [ENTER] Button to determine the setting.

- While a Menu is displayed, you cannot record or play back. Menus can be displayed during playback but not during recording. The above operations can be done using the [MENU] Button, [▲], [◀], [▶], [▼] Buttons and [ENTER] Button on the Remote Controller. (-12-)

#### To Return the Previous Screen

Press the [◀◀] Button.

#### To Exit the Menu Screen

Press the [MENU] Button again.

#### About the Menu Mode Setting

The setting selected on the Menu will be retained even when the Camcorder is turned off. (The setups of [EFFECT2] (-30-) are not retained.) However, if the Battery or AC Adaptor is disconnected before turning off the Camcorder, the selected setup may not be retained.

- Menu operation flow is shown in this text by >>.

## List of Menus

The figures of the Menus are for explanation purposes only, and they are different from the actual Menus.

### ■ [TAPE RECORDING MENU]

Tape Recording Menu

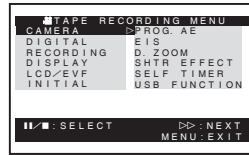

#### 1) [CAMERA]

Camera Setup Sub-Menu

##### [PROG.AE]

Auto Exposure Mode -27-

##### [EIS]

Image Stabilizer -24-

##### [D.ZOOM]

Digital Zoom -24-

##### [SHTR EFFECT]

Shutter Effect -22-

##### [SELF TIMER]

Self-timer Recording -23-

##### [USB FUNCTION]

USB Functions Mode -39-

- If you press [◀◀] Button, the menu changes back to the previous screen.

#### 2) [DIGITAL]

Digital Setup Sub-Menu

##### [EFFECT1]

Digital Effects 1 -30-

##### [EFFECT2]

Digital Effects 2 -30-

##### [MULTI MODE]

Multi-Picture Mode -30-

#### 3) [RECORDING]

Recording Setup Sub-Menu

##### [REC SPEED]

Recording Speed Mode -20-

##### [AUDIO REC]

Audio Recording Mode -20-

##### [SCENE INDEX]

Scene Index Mode -34-

##### [WIND CUT]

Wind Noise Reduction -26-

##### [ZOOM MIC]

Zoom Microphone -24-

##### [CINEMA]

Cinema-like Format Recording -27-

#### 4) [DISPLAY]

Display Setup Sub-Menu

##### [DISPLAY]

Display Mode -47-

##### [DATE/TIME]

Date and Time Indication -47-

##### [C.DISPLAY]

Counter Display Mode -46-

**[C.RESET]**

Counter Reset -57-

- It resets the counter to zero. However, it cannot reset the Time Code.

**5) [LCD/EVF]**

LCD/EVF Setup Sub-Menu

**[LCD/EVF SET]**

LCD and Viewfinder Adjustment -17-

**[SELF REC]**

Recording Yourself -23-

**[EVF ON/AUTO]**

Using the Viewfinder -17-

**6) [INITIAL]**

Initial Setup Sub-Menu

**[BLANK SEARCH]**

Blank Search -22-

**[DEMO MODE]**

Demonstration Mode

- If no operation takes place for approximately 10 minutes after the AC Adaptor is connected to the Camcorder and the [OFF/ON] Switch is turned to [ON] without inserting a Cassette, the Camcorder is automatically set to Demonstration Mode for introducing its functions. If any button is pressed or operated, the Demonstration Mode is cancelled. The Demonstration Mode can be started by setting [DEMO MODE] to [ON] and by exiting the Menu. To terminate the Demonstration Mode, insert a Cassette or set the [DEMO MODE] to [OFF].

**[AV JACK]**

AV Jack -55-

**[REMOTE]**

Remote Controller Mode -13-

**[REC LAMP]**

Recording Lamp -21-

**[BEEP SOUND]**

Beep Sound -48-

**[CLOCK SET]**

Date and Time Setting -20-

**[INITIAL SET]**

Initial Setting Mode -47-

**[TAPE PLAYBACK MENU]**

Tape Playback Menu

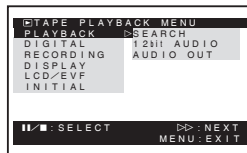
**1) [PLAYBACK]**

Playback Functions Sub-Menu

**[SEARCH]**

Index Search Mode -34-

**[12bit AUDIO]**

Audio Selector -37-

**[AUDIO OUT]**

Audio Output Mode -50-

**2) [DIGITAL]**

Playback Digital Setup Sub-Menu

**[EFFECT ON]**

Digital Effect On/Off -35-

**[EFFECT SEL]**

Digital Effect Selection -35-

**3) [RECORDING]**

Recording Setup Sub-Menu

**[REC SPEED]**

Recording Speed Mode -20-

**[AUDIO REC]**

Audio Recording Mode -20-

**4) [DISPLAY]**

Display Setup Sub-Menu

**[DISPLAY]**

Display Mode -47-

**[DATE/TIME]**

Date and Time Indication -47-

**[C.DISPLAY]**

Counter Display Mode -46-

**[C.RESET]**

Counter Reset -57-

**5) [LCD/EVF]**

Adjusting Brightness and Color Level

**[LCD/EVF SET]**

LCD and Viewfinder Adjustment -17-

**[EVF ON/AUTO]**

Using the Viewfinder -17-

**6) [INITIAL]**

Initial Setup Sub-Menu

**[BLANK SEARCH]**

Blank Search -22-

**[AV JACK]**

AV Jack -50-

**[REMOTE]**

Remote Controller Mode -13-

**[REC LAMP]**

Recording Lamp -21-

**[BEEP SOUND]**

Beep Sound -48-

## Setting Date and Time

Since the internal clock of the Camcorder has a slight imprecision make sure to check the time before recording.

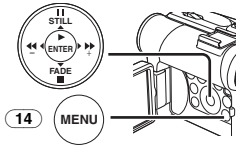

- 1 Set [TAPE RECORDING MENU] >> [INITIAL] >> [CLOCK SET] >> [YES].

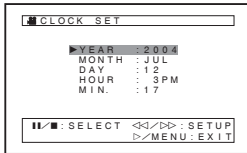

- 2 Press the [II/■] Button to select [YEAR], [MONTH], [DAY], [HOUR] or [MIN.] and press the [◀/▶] Button to set it to the desired value.
  - Year will cycle in the order shown below. 2000, 2001, ..., 2089, 2000, ...
- 3 Press the [MENU] Button (14) to finish setting the date and time.
  - The clock operation starts from [00] second.
  - If the built-in battery is weak, the [⊕] or [--] Indication flashes. In this case, charge the built-in battery.
  - The clock uses the 12-hour system.

## Internal Lithium Battery Recharge

The internal lithium battery sustains the operation of the clock. When the [⊕] or [--] Indication flashes, the internal lithium battery is near exhaustion.

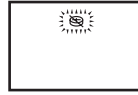

- 1 Connect the AC Adaptor to the Camcorder with the power turned off and then connect to the AC Jack.

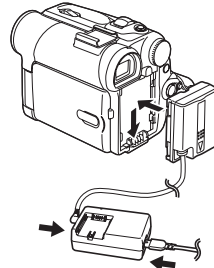

- After charging for 4 hours, the built-in lithium battery can power the clock for approximately 3 months.

## LP Mode

A desired recording speed can be selected with [REC SPEED] on the [RECORDING] Sub-Menu. **If LP Mode is selected, the recording time becomes 1.5 times longer than that of SP Mode.**

Although the image quality does not decrease with the LP Mode recording, mosaic-pattern noise may appear on a playback image, or some normal functions may be restricted.

- The contents that are recorded in LP Mode are not completely compatible with other equipment.
  - Audio dubbing is not possible with LP Mode.
- (-37-)

## Audio Recording Mode

The sound quality of the recorded sound can be selected with [AUDIO REC] on the [RECORDING] Sub-Menu.

High sound-quality recording is possible with "16 bit 48 kHz 2 track" Mode. With the "12 bit 32 kHz 4 track" Mode, the original sound can be recorded on 2 tracks in stereo, while the other 2 tracks can be used for Audio Dubbing.

## Recording Mode

### About Recording

When recording pictures on a tape, set the Mode Dial to Tape Recording Mode [  ].

When recording with the [AUTO/MANUAL/FOCUS] Switch (44) set to [AUTO], the Camcorder automatically adjusts the focus and white balance. In some cases, they cannot be adjusted automatically and need to be adjusted manually. (-28-, -29-)

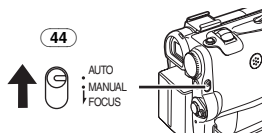

- Before turning on the power, remove the Lens Cap. If the Lens Cap is still attached when the power is turned on, Automatic White Balance Adjustment (-28-) may not function correctly.
- When the Recording Pause Mode continues for more than 5 minutes, the power is turned off automatically for tape protection and power conservation. (If the AC Adaptor is used, the power is turned off only when the tape is inserted in Tape Recording Mode.) When the tape is inserted in Tape Recording Mode and if the Recording Pause Mode continues for more than 5 minutes the power is turned off automatically. To resume recording from this condition, turn off, then turn on the power again.

### Recording Lamp

The Recording Lamp (16) lights up during recording and alerts those being recorded that recording is in progress.

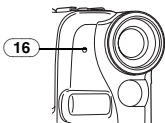

- The Recording Lamp does not light up if the [REC LAMP] on the [INITIAL] Sub-Menu is set to [OFF].

### Recording on a Tape

#### 1 Set the [OFF/ON] Switch (42) to [ON].

- The [POWER] Lamp (43) lights up.

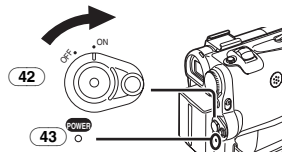

#### 2 Set the Mode Dial (39) to Tape Recording Mode.

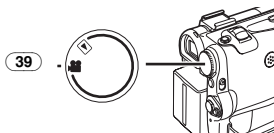

#### 3 Press the Recording Start/Stop Button (41).

- Recording starts.
- After [RECORD] is displayed, it changes to [REC].

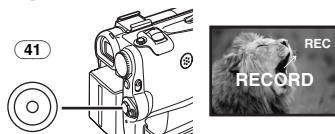

#### 4 Press the Recording Start/Stop Button (41) again to pause the recording.

- The [PAUSE] Indication is displayed.



### To Check the Recording

By pressing the [G] Button (7) briefly in the Recording Pause Mode, you can play back the last few seconds of the recorded scene.



- The [CHK] Indication is displayed. After checking, the Camcorder resumes the Recording Pause Mode.

## ■ Finding the End of Recording (Blank Search Function)

The Blank Search Function aids you in locating the end of the recording on the Cassette quickly.

- 1 Set [TAPE RECORDING MENU] or [TAPE PLAYBACK MENU] >> [INITIAL] >> [BLANK SEARCH] >> [YES].

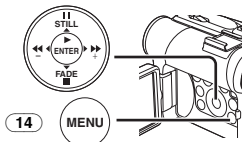

- The [BLANK] Indication appears during the Blank Search.
- Approximately 1 second before the last recorded scene, the Camcorder switches to the Recording Pause Mode or the Still Playback Mode.
- If there is no blank left on the Cassette, the Camcorder stops at the end of the tape.

### To Cancel Blank Search Before Completion

Press the [■] Button.

### ■ To Add a Sound while Recording

With the supplied Magic Wire Remote Control with Narration Mic (optional) connected to the [REMOTE] Jack (30), you can add a narration while recording is in progress.

While the [TALK] Button (80) is pressed, the [⏏] Indication is displayed and the sound is recorded from [MIC] (76).

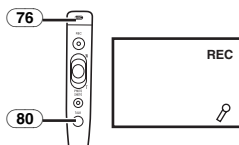

- While the [TALK] Button is pressed, the built-in microphone does not operate.

## Photoshot

Still pictures can be recorded from the Camcorder lens.

- 1 Press the [PHOTO SHOT] Button (35) in the Recording Pause Mode.

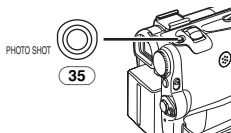

- The Camcorder records a still picture for about 7 seconds and then switches back to the Recording Pause Mode.

- If you set [SHTR EFFECT] on the [CAMERA] Sub-Menu to [ON], you can add an image and a sound like releasing the shutter.

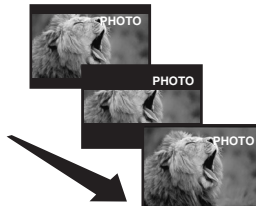

## ■ Progressive Photoshot

When the [P] Indication is displayed, Progressive Photoshot Function works. You can record still pictures with higher quality by using this function.

- The Progressive Photoshot Function may not be activated depending on the function you use. (-47-)

## ■ Continuous Photoshot

If you set [SHTR EFFECT] on the [CAMERA] Sub-Menu to [ON] and keep the [PHOTO SHOT] Button pressed, the Camcorder will continuously record still pictures in approximately 0.7 seconds intervals until the button is released.

- The screen blinks and, at the same time, a shutter clicking sound is recorded.

## ■ Digital Still Picture

When the [STILL] Button (9) is pressed, images become still pictures. When the button is pressed again, the Digital Still Picture Mode is cancelled.

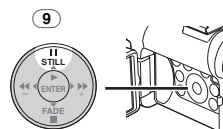

- We recommend that you press the [STILL] Button first at the position where you wish to record the still picture so as to enter the Digital Still Picture Mode and then press the [PHOTO SHOT] Button.

- For other notes concerning this item, see -48-.

## Recording Yourself

By opening the LCD Monitor and rotating it forward (to the lens side), you can let the subject in front of the Camcorder monitor the shot while recording is in progress.

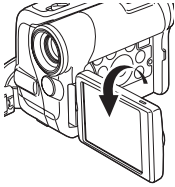

- When the LCD Monitor is opened, the Viewfinder is disabled automatically. However, when the LCD Monitor is rotated forward, the image is also shown in the Viewfinder.
- If you prefer to have the image on the LCD Monitor to look like an image in a mirror, set [SELF REC] on the [LCD/EVF] Sub-Menu to [MIRROR]. Images are recorded normally and no left and right reversal occurs.

## Quick Start

By pressing the [QUICK START] Button (40), the Camcorder will be ready for recording in approximately 1.3 seconds after it is turned on.

### 1 Press the [QUICK START] Button (40).

- The Quick Start Recording Lamp (40) lights up.

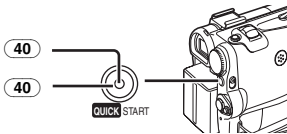

### 2 Set the [OFF/ON] Switch (42) to [OFF].

- The Quick Start Recording Lamp remains lit.

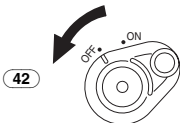

### 3 Set the [OFF/ON] Switch (42) to [ON].

- The Camcorder will be ready for recording in approximately 1.3 seconds.

### To Cancel the Quick Start

Keep the [QUICK START] Button pressed for approximately 2 seconds and make sure the Quick Start Recording Lamp is not lit.

- For other notes concerning this item, see -48-.

## Self-timer Recording

When you set the self-timer, the still pictures are automatically taken after 10 seconds, on the Tape.

### 1 Set [TAPE RECORDING MENU] >> [CAMERA] >> [SELF TIMER] >> [ON].

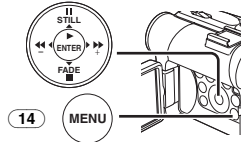

- The [ ] Indication appears.

### 2 Press the [PHOTO SHOT] Button (35).

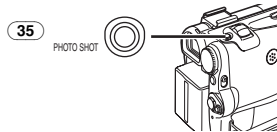

- The Recording Lamp (16) and the [ ] Indication flash and the recording starts after 10 seconds.

- For other notes concerning this item, see -48-.

## Zoom In/Out Functions

This feature gives special effects to the picture by recording objects close by or with wide-angle shot.

### 1 For wide-angle shots (zoom out):

Push the [W/T] Lever (36) towards [W].

For close-ups (zoom in):

Push the [W/T] Lever towards [T].

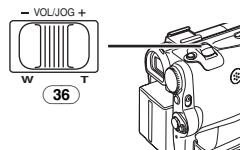

- Zoom Magnification Indication is displayed for a few seconds.



## ■ To Take Close-up Shots of Small Subjects

### (Macro Close-up Function)

When the zoom magnification is 1×, the Camcorder can focus on a subject that is as close as approximately 1.6 inches (4 cm) from the Lens. Small subjects like insects can be recorded with this function.

### ■ To Use the Tele-Macro Function

With the zoom magnification of 10×, the Camcorder can bring the subject into focus as close as approximately 7.8 inch (20 cm) from the Lens. Focusing only on the subject and displaying the background out of focus makes the picture more impressive.

1 Press the [TELE MACRO] Button (5).

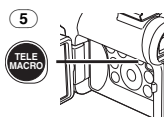

- The zoom magnification is fixed at 10× and the subject can be focused on as close as 7.8 inch (20 cm).
- The [TELE MACRO] Indication appears.



2 Press the Recording Start/Stop Button (41) or the [PHOTO SHOT] Button (35).

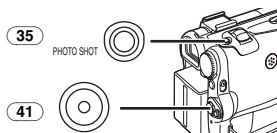

### To Cancel the Tele-Macro Function

Press the [TELE MACRO] Button.

### ■ To Use the Zoom Microphone Function

Along with the zooming operation, the microphone's directional angle and sensitivity are varied for recording sounds.

- Set [TAPE RECORDING MENU] >> [RECORDING] >> [ZOOM MIC] >> [ON]. (The [Z.MIC] Indication is displayed.)



- For other notes concerning this item, see -48-.

## Digital Zoom Function

This function is useful when you want to record close-up shots of subjects located beyond a normal zoom range of 1× to 10× magnification. With the Digital Zoom Function, you can select a magnification from 25× up to 700×.

1 Set [TAPE RECORDING MENU] >> [CAMERA] >> [D.ZOOM] >> [25×] or [700×].

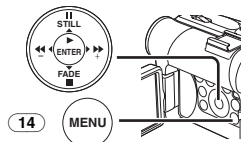

- 25×: Digital zooming to 25×
- 700×: Digital zooming to 700×



2 Push the [W/T] Lever (36) towards [W] or towards [T] to zoom in or out.

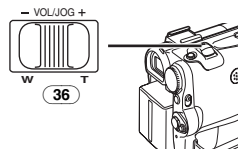

### To Cancel the Digital Zoom Function

Set [TAPE RECORDING MENU] >> [CAMERA] >> [D.ZOOM] >> [OFF].

- For other notes concerning this item, see -48-.

## Image Stabilizer Function

If the Camcorder is shaken while recording, the camera shake in the image can be corrected.

- If the Camcorder shakes too much, the images may not be stabilized.

1 Set [TAPE RECORDING MENU] >> [CAMERA] >> [EIS] >> [ON].

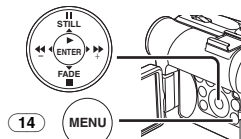

- The [EIS] Indication appears.





- 2 Press the Recording Start/Stop Button (41) or [PHOTO SHOT] Button (35) to start recording.**

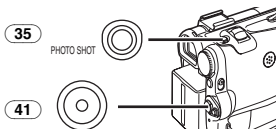

**To Cancel Image Stabilizer Function**  
Set [TAPE RECORDING MENU] >> [CAMERA]  
>> [EIS] >> [OFF].

- For other notes concerning this item, see -48-.

## Fade In/Out Functions

### Fade In

Fade In brings out images and sounds gradually from a black screen at the beginning of a scene.



- 1 Keep pressing the [FADE] Button (12) during the Recording Pause Mode.**

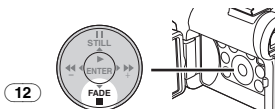

- The image fades out gradually.
- 2 When the image is completely gone, press the Recording Start/Stop Button (41) to start recording.**

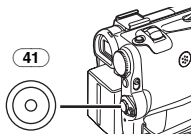

- 3 Release the [FADE] Button (12) about 3 seconds after starting recording.**

- The image reappears gradually.

### Fade Out

Fade Out causes images and sounds to disappear gradually, leaving a black screen at the end of a scene.

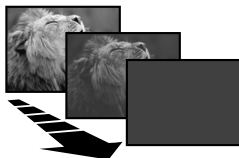

- 1 Keep pressing the [FADE] Button (12) while recording.**

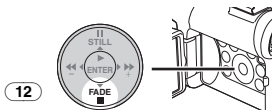

- The image fades out gradually.
- 2 When the image is completely gone, press the Recording Start/Stop Button (41) to stop recording.**

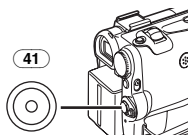

- 3 Release the [FADE] Button (12).**

- The still picture cannot fade in or fade out.

## Backlight Compensation Function

This prevents the subject from being recorded too darkly when backlit. (Backlight is the light that shines from behind the subject being recorded.)

- 1 Press the [BACK LIGHT] Button (8).**



- The [Back Light] Indication flashes and then is displayed.
- The entire screen becomes brighter.



### To Resume Normal Recording

Press the [BACK LIGHT] Button.

- For other notes concerning this item, see -48-.

## MagicPix Functions

### MagicPix Function

This function allows you to record color images brightly in a dark place without using the Video Flash.

- 1 Press the [MAGICPIX] Button **3** until the [MAGICPIX] Indication appears.

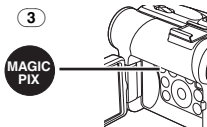

### 0 Lux MagicPix Function

Using the LCD Monitor light, a dark scene of almost 0 lux can be recorded.

- 1 Press the [MAGICPIX] Button **3** until the [0LUX MAGICPIX] Indication appears.



- The [REVERSE THE LCD MONITOR] Indication appears.

- 2 Rotate the LCD Monitor forward (to the lens side).

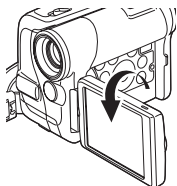

- The screen becomes white and the Viewfinder turns on.
- The available range of the LCD Monitor light is within approximately 3.9 feet (1.2 meter).

### To Cancel the MagicPix Functions

Press the [MAGICPIX] Button repeatedly until neither the [MAGICPIX] Indication nor the [0LUX MAGICPIX] Indication appears.

- For other notes concerning this item, see -49-.

## Soft Skin Function

This enables you to record skin colors in a softer tone. In order to get the best result, avoid background colors similar to the skin color of the subject. Otherwise, this may result in a softer background lacking in detail.

- 1 Press the [SOFT SKIN] Button **4**.



- The [SOFT SKIN] Indication appears.



- To obtain the best effect, we recommend to take a bust shot, so that the upper part from the breast of the subject can be framed in the screen.

### To Cancel the Soft Skin Function

Press the [SOFT SKIN] Button.

## Wind Noise Reduction Function

This function reduces the sound of wind hitting the microphone when recording.

- 1 Set [TAPE RECORDING MENU] >> [RECORDING] >> [WIND CUT] >> [ON].

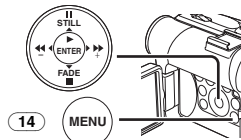

- The [WIND CUT] Indication appears.



### To Cancel the Wind Noise Reduction Function

Set [TAPE RECORDING MENU] >> [RECORDING] >> [WIND CUT] >> [OFF].

- For other notes concerning this item, see -49-.

## Cinema Function

This function is for recording a cinema-like image.

- 1 Set [TAPE RECORDING MENU] >> [RECORDING] >> [CINEMA] >> [ON].

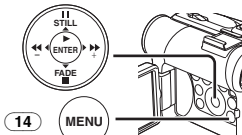

- Black bars appear at the top and bottom of the screen.



### To Cancel the Cinema Mode

- Set [TAPE RECORDING MENU] >> [RECORDING] >> [CINEMA] >> [OFF].

- For other notes concerning this item, see -49-.

## Recording in Special Situations

### (Program AE)

You can select optimal automatic exposure under specific recording situations.

- 1 Set the [AUTO/MANUAL/FOCUS] Switch (44) to [MANUAL].



- The [MNL] Indication appears.

- 2 Set [TAPE RECORDING MENU] >> [CAMERA] >> [PROG.AE] >> a desired mode ([], [], [], [] or []).

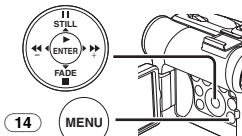

- The Indication of the selected Mode appears.

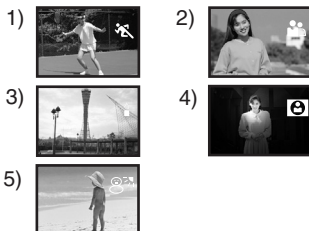

- 1) [] Sports Mode

- For recording scenes involving quick movements, such as sports scenes.

- 2) [] Portrait Mode

- Use when you want to make people (subjects) stand out from the background.

- 3) [] Low Light Mode

- For brightening a dark scene.

- 4) [] Spotlight Mode

- For recording a subject under a spotlight.

- 5) [] Surf & Snow Mode

- For recording in glaring surroundings, such as ski slopes, beaches, etc.

### To Cancel the Program AE Function

Set the [PROG.AE] on the [CAMERA] Sub-menu to [OFF]. Or, set the [AUTO/MANUAL/FOCUS] Switch to [AUTO].

- For other notes concerning this item, see -49-.

## Recording in Natural Colors

### (White Balance)

Depending on the scene or light condition, the Automatic White Balance Adjustment Mode may not be able to bring out natural colors. In this case, the white balance can be adjusted manually.

When the Camcorder is turned on with the Lens Cap on, the Automatic White Balance Adjustment may not function properly. Please turn on the Camcorder after removing the Lens Cap.

- 1 Set the [AUTO/MANUAL/FOCUS] Switch (44) to [MANUAL].



- The [MNL] Indication appears.

- 2 Press the [ENTER] Button (11).

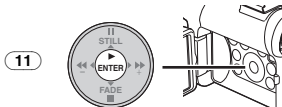

- The [AWB] Indication appears.

- 3 Press the [▶▶] Button (10) or [◀◀] Button (13) to select a desired White Balance Mode.

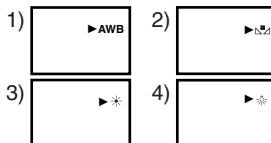

- 1) Automatic White Balance Adjustment [AWB]
- 2) The white balance setting that was previously set manually [MNL]
- 3) Outdoor Mode [☆]
- 4) Indoor Mode (recording under incandescent lamp) [☀]

### To Resume Automatic Adjustment

Press the [▶▶] Button (10) or [◀◀] Button (13) until the [AWB] Indication appears. Or, set the [AUTO/MANUAL/FOCUS] Switch to [AUTO].

### Adjusting White Balance Manually

White Balance Adjustment recognizes the color of light and adjust so that the white color will become pure white. The Camcorder determines the hue of light that comes through the Lens and White Balance Sensor, thereby judging the recording condition, and selects the closest hue setting. This function is called Automatic White Balance Adjustment.

For light outside the functional Auto White Balance Adjustment range, use the Manual White Balance Adjustment Mode.

- 1 Set the [AUTO/MANUAL/FOCUS] Switch (44) to [MANUAL].



- The [MNL] Indication appears.

- 2 Press the [ENTER] Button (11).

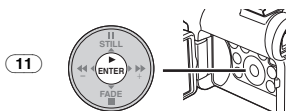

- The [AWB] Indication appears.

- 3 Press the [▶▶] Button (10) or [◀◀] Button (13) until the [MNL] Indication is displayed.



- 4 Point the Camcorder at a full-screen white subject.

- 5 Keep pressing [ENTER] Button (11) until the [MNL] Indication stops flashing.

### To Resume Automatic Adjustment

Press the [▶▶] Button (10) or [◀◀] Button (13) until the [AWB] Indication is displayed. Or, set the [AUTO/MANUAL/FOCUS] Switch to [AUTO].

## About White Balance Sensor

The White Balance Sensor (29) determines the nature of the light source during recording.



- Do not cover the White Balance Sensor with your hand during recording because White Balance will not function normally.
- The red light from the Recording Lamp (16) will be reflected off your hand or object, possibly causing the White Balance sensor to operate incorrectly and changing the coloring.

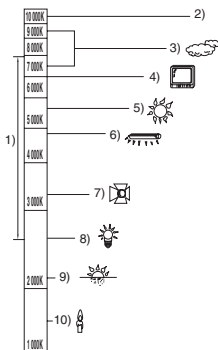

Outside of the effective range of Automatic White Balance Adjustment, the image will become reddish or bluish. Even within the effective range of Automatic White Balance Adjustment, the Automatic White Balance Adjustment may not function properly if there is more than one light source. In this case, adjust the White Balance.

- 1) The effective range of Automatic White Balance Adjustment on this Camcorder
- 2) Blue sky
- 3) Cloudy sky (rain)
- 4) TV screen
- 5) Sunlight
- 6) White fluorescent lamp
- 7) Halogen light bulb
- 8) Incandescent light bulb
- 9) Sunrise or sunset
- 10) Candlelight

- For other notes concerning this item, see -49-.

## Manual Shutter Speed Adjustment

Useful for recording fast-moving subjects.

- 1 Set the [AUTO/MANUAL/FOCUS] Switch (44) to [MANUAL].

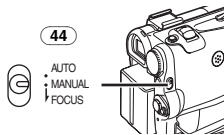

- The [MNL] Indication appears.

- 2 Press the [ENTER] Button (11) until the Shutter Speed Indication appears.

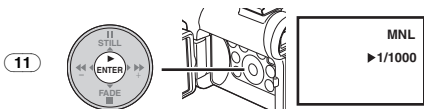

- 3 Press the [▶▶] Button (10) or [◀◀] Button (13) to adjust the shutter speed.

### Range of Shutter Speed Adjustment

1/60–1/8000 s

The standard shutter speed is 1/60 s.

Selecting a speed closer to [1/8000] causes the shutter speed to be faster.

### To Resume Automatic Adjustment

Set the [AUTO/MANUAL/FOCUS] Switch to [AUTO].

- For other notes concerning this item, see -49-.

## Manual Iris Adjustment

### (F Number)

You can use this function when the screen is too bright or too dark.

- 1 Set the [AUTO/MANUAL/FOCUS] Switch (44) to [MANUAL].

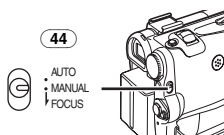

- The [MNL] Indication appears.

- 2 Press the [ENTER] Button (11) until the Iris Indication appears.

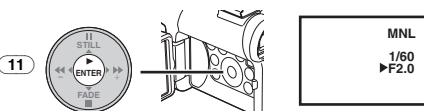

- 3 Press the [▶▶] Button (10) or [◀◀] Button (13) to adjust the iris.

### Range of Iris Adjustment

CLOSE (Closed), F16, ..., F2.0,

OP (Opened)+0dB, ..., OP+18dB

When a value closer to [CLOSE] is selected, the image becomes darker.

When a value closer to [OP+18dB] is selected, the image becomes brighter.

The value to which +dB is attached indicates a Gain-up value. If this value is too large, the quality of the image deteriorates.

### To Resume Automatic Adjustment

Set the [AUTO/MANUAL/FOCUS] Switch to [AUTO].

- For other notes concerning this item, see -50-.

## Manual Focus Adjustment

Focus can be adjusted manually for recording in a situation where auto focus may not function well.

- 1 Set the [AUTO/MANUAL/FOCUS] Switch (44) to [MANUAL].



- The [MNL] Indication appears.

- 2 Slide the [AUTO/MANUAL/FOCUS] Switch (44) to [FOCUS].

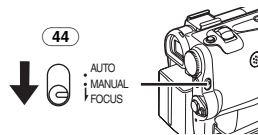

- The [▶MF] Indication (Manual Focus Mode) appears.



- 3 Press the [▶▶] Button (10) or [◀◀] Button (13) to adjust the focus.

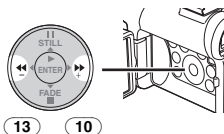

- If you keep pressing the [▶▶] Button or [◀◀] Button, the speed of adjusting will be faster.

### To Resume Automatic Adjustment

Set the [AUTO/MANUAL/FOCUS] Switch to [AUTO] or [FOCUS].

## Digital Effect Functions

This Camcorder is equipped with Digital Effect Functions that add special effects to the scene.

### Digital Effects 1 [EFFECT1]

1) MULTI



2) P-IN-P



3) WIPE



4) MIX



5) STROBE



6) TRAIL



7) MOSAIC



8) MIRROR



9) STRETCH



10) SLIM



- 1) Multi Mode [MULTI]
  - It records an image in black and white.
- 2) Picture-In-Picture Mode [P-IN-P]
  - It records an image with a painting-like effect.
- 3) Wipe Mode [WIPE]
  - It records an image in black and white.
- 4) Mix Mode [MIX]
  - It records an image with a painting-like effect.
- 5) Strobe Mode [STROBE]
  - Records images with a stroboscopic effect.
- 6) Trailing Effect Mode [TRAIL]
  - Records images with a trailing effect.
- 7) Mosaic Mode [MOSAIC]
  - Produces a mosaic-like image.
- 8) Mirror Mode [MIRROR]
  - The right half of an image becomes a mirror image of the left half.
- 9) Stretch Mode [STRETCH]
  - The picture is expanded horizontally.
- 10) Slim Mode [SLIM]
  - The picture is expanded vertically.

### Digital Effects 2 [EFFECT2]

11) NEGA



12) SEPIA



13) B/W



14) SOLARI



- 11) Negative Mode [NEGA]
  - The colors of the recorded image are inverted as seen in a negative.
- 12) Sepia Mode [SEPIA]
  - It records a scene with a brownish tint, like the color of old pictures.
- 13) Black & White Mode [B/W]
  - It records an image in black and white.
- 14) Solarisation Mode [SOLARI]
  - It records an image with a painting-like effect.

- It records an image in black and white.
- 14) Solarisation Mode [SOLARI]
    - It records an image with a painting-like effect.

### To Select a Desired Digital Effect

Set [TAPE RECORDING MENU] >> [DIGITAL] >> [EFFECT1] or [EFFECT2] >> a desired Digital Effect.

### To Cancel the Digital Effect

Set [TAPE RECORDING MENU] >> [DIGITAL] >> [EFFECT1] or [EFFECT2] >> [OFF].

- If the Camcorder is turned off, the [EFFECT2] settings are cancelled.

- For other notes concerning this item, see -50-.

## Multi-Picture Mode

### Strobe Multi-Picture Mode:

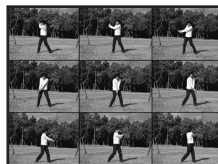

You can capture and record 9 consecutive small still pictures.

### Manual Multi-Picture Mode:



You can manually capture and record 9 small still pictures.

- 1 Set [TAPE RECORDING MENU] >> [DIGITAL] >> [EFFECT1] >> [MULTI].

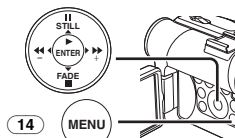

- 2 Set [TAPE RECORDING MENU] >> [DIGITAL] >> [MULTI MODE] >> [STROBE] or [MANUAL].

- 3 Press the [MULTI] Button ⑥.

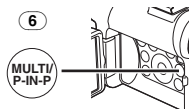

- If [MANUAL] is selected, press the [MULTI] Button at each scene you want to capture.

**Deleting All the Captured Multi-Pictures**

While 9 multi-pictures are displayed, press the [MULTI] Button.

- If [MANUAL] has been selected, press the [MULTI] Button after 9 pictures are displayed.

**To Display the Multi-Pictures Again**

Press the [MULTI] Button for 1 second or longer.

**To Delete Multi-Pictures One by One**

(When pictures were captured in [MANUAL])

When the [MULTI] Button is pressed for 1 second or longer while the still pictures are displayed, the pictures captured last are deleted continuously.

- After still pictures are deleted one by one, they cannot be displayed again.

- For other notes concerning this item, see -50-.

**Picture-in-Picture Mode**

You can display a sub-screen (still picture) inside the screen.

- 1 Set [TAPE RECORDING MENU] >> [DIGITAL] >> [EFFECT1] >> [P-IN-P].

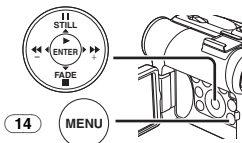

- 2 Aim the Camcorder at the scene you want to capture and press the [P-IN-P] Button (6) to insert a small still picture.

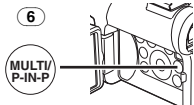

- A small still picture is displayed in a normal picture.
  - If the [P-IN-P] Button is pressed again, the small still picture is cleared.
- For other notes concerning this item, see -50-.

**Wipe Mode and Mix Mode****Wipe Mode:**

Like drawing a curtain, the still picture of the last recorded scene gradually changes to the moving image of a new scene.

**Mix Mode:**

While the moving image of a new scene fades in, the still image of the last recorded scene gradually fades out.

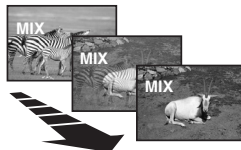

- 1 Set [TAPE RECORDING MENU] >> [DIGITAL] >> [EFFECT1] >> [WIPE] or [MIX].

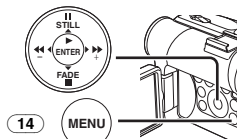

- The [WIPE] or [MIX] Indication appears.
- 2 Press the Recording Start/Stop Button (41) to start recording.

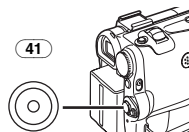

- 3 Press the Recording Start/Stop Button (41) to pause the recording.

- The last scene is stored in memory. The [WIPE] or [MIX] Indication changes to [WIPE] or [MIX].

- 4 Press the Recording Start/Stop Button (41) to restart the recording.

- The last image of the previous scene gradually changes to the new scene.

- For other notes concerning this item, see -50-.



## Playback Mode

### Playing Back a Tape

The recorded scene can be played back immediately after the recording.

**1 Set the [OFF/ON] Switch (42) to [ON].**

- The [POWER] Lamp (43) lights up.

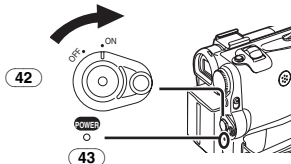

**2 Set the Mode Dial (39) to Tape Playback Mode.**

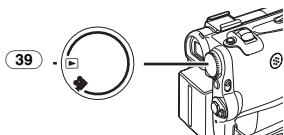

**3 Press the [◀◀] Button (13) to rewind the tape.**

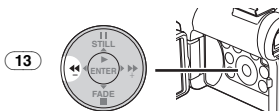

- Rewind the tape to the point where you want to start playback.
- When the tape reaches the beginning, rewinding stops automatically.

**4 Press the [▶] Button (11) to start playback.**

- The [▶] Indication appears.

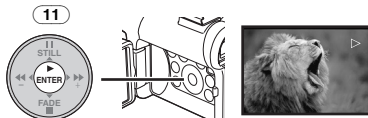

- If a cassette recorded with a copyright protection signal is played back, the picture is distorted by mosaic-like patterns.

**To Stop Playback**

Press the [■] Button (12).

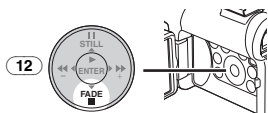

### Adjusting the Sound Volume

To adjust the volume, push the [-VOL/JOG+] Lever (36) to display the [VOLUME] Indication. Push the [-VOL/JOG+] Lever towards [T] to increase the volume or push the [-VOL/JOG+] Lever towards [W] to decrease the volume. The [VOLUME] Indication goes off after the adjustment is finished.

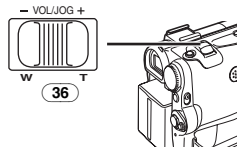

To adjust the volume with the Remote Controller, press the [T] or [W] Button to display the [VOLUME] Indication. Press the [T] Button to increase the volume or press the [W] Button to decrease the volume. The [VOLUME] Indication goes off after the adjustment is finished.



- The sound volume cannot be adjusted using the Remote Controller in Playback Zoom Mode. (-34-)

- For other notes concerning this item, see -50-.

### Finding a Scene You Want to Play Back

#### Cue/Review Playback

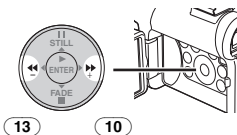

If the [▶▶] Button (10) or [◀◀] Button (13) is pressed during Playback, it turns to Cue Playback (A) or Review Playback (B).

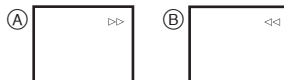

- If the Button is held continuously, it turns to Cue Playback or Review Playback until you release it.



## Variable Speed Search Function

The speed of Cue Playback or Review Playback can be varied.

### 1 During playback, press the [▶] Button (11).

- The [1×▷] Indication appears.

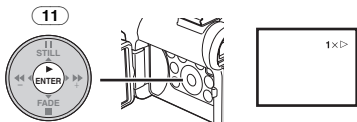

### 2 Push the [W/T] Lever (36) to select a desired search speed.

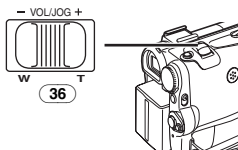

The following 6 playback speeds are available for the Variable Speed Search Function in both the fast-forwarding and rewinding directions:

1/5× (slow playback in SP Mode only), 1/3× (slow playback in LP Mode only), 1×, 2×, 5×, 10× and 20×.

- This function works by pressing the [VAR. SEARCH] and cursor buttons ([▲], [▼]) on the Remote Controller. (-12-)

### To Resume Normal Playback

Press the [▶] Button (11).

- During Cue or Review Playback, fast-moving images may show mosaic-like patterns.
- The sound is muted during search.

## Slow Motion Playback

This Camcorder can play back at a slow speed.

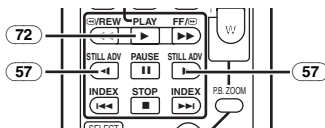

### 1 Press the [▶] Button (72). 2 Press the [◀] Button or [▶] Button (57) on the Remote Controller.

- The [◀◀] or [▶▶] Indication appears.



- When the [◀] Button is pressed, Slow Motion Playback proceeds in the reverse direction. When the [▶] Button is pressed, Slow Motion Playback proceeds in the forward direction.

Scenes recorded in the SP Mode are played back at approximately 1/5th of the normal speed. Scenes recorded in the LP Mode are played back at approximately 1/3rd of the normal speed.

### To Resume Normal Playback

Press the [▶] Button (72).

- If the Camcorder is left in the Slow Motion Playback Mode for more than 10 minutes, the Camcorder switches to the Stop Mode to protect the video heads from excessive wear and tear.

## Still Playback/Still Advance Playback

This Camcorder is capable of still picture playback and frame-advance playback.

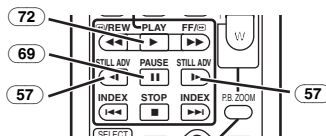

### 1 Press the [▶] Button (72). 2 Press the [II] Button (69). 3 Press the [◀] Button or [▶] Button (57) on the Remote Controller.

- The Playback image stops in the Still Playback Mode.
- With each press of the [◀] Button, still pictures advance in the reverse direction. With each press of the [▶] Button, still pictures advances in the forward direction. If one of the buttons continues to be pressed, still pictures advance continuously 1 frame at a time until the button is released.

### To Resume Normal Playback

Press the [▶] Button (72).

## Playback with Zoom Lever

By pushing the [W/T] Lever (36) of the Camcorder in the Still Playback Mode, still pictures can be advanced one frame at a time in the forward or backward direction. If you keep pushing the Lever, still pictures advance continuously.

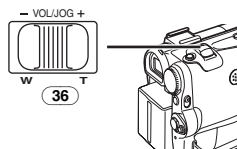

- If the Camcorder is left in the Still Playback Mode for more than 5 minutes, the Camcorder switches to the Stop Mode to protect the video heads from excessive wear and tear.

## Index Search Functions

To facilitate searching for desired scenes, this Camcorder automatically records index signals during recording, as explained in the following.

### Photoshot Index Signal

These signals are automatically recorded whenever still pictures are taken in Photoshot Mode (-22-). Photoshot Index Signals are not recorded on still pictures recorded in Continuous Photoshot Mode.

### Scene Index Signal

Scene Index Signals are automatically recorded when you start recording after inserting a Cassette.

- If [SCENE INDEX] of [RECORDING] Sub-Menu on the [TAPE RECORDING MENU] is set to [2HOUR], an index signal is recorded when recording is restarted after an elapse of 2 hours or longer. If it is set to [DAY], an index signal is recorded when recording is restarted after the date has changed since the last recording. (While the index signal is being recorded, the [INDEX] Indication flashes for a few seconds.)



- If the Camcorder is switched from the Tape Playback Mode to Tape Recording Mode or if the date and time is set before the start of recording, the index signal is not recorded.

### Photoshot Index Search

- 1 Set [TAPE PLAYBACK MENU] >> [PLAYBACK] >> [SEARCH] >> [PHOTO].

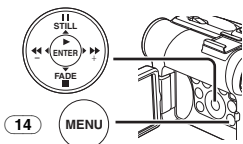

- 2 Press the [▶▶] Button or [◀◀] Button (58) on the Remote Controller.

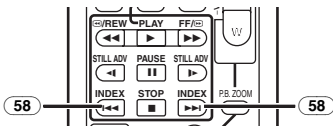

- With each press of the corresponding button, still pictures recorded in Photoshot Mode are searched.
- Sounds are played back for approximately 4 seconds.

### Scene Index Search

- 1 Set [TAPE PLAYBACK MENU] >> [PLAYBACK] >> [SEARCH] >> [SCENE].
- 2 Press the [▶▶] Button or [◀◀] Button (58) on the Remote Controller.

- When the corresponding button is pressed once, the [S 1] Indication appears, and searching for the subsequent scene marked with an index signal starts. Each time the button is pressed after the start of Scene Index Search, the indication changes, from [S 2] to [S 9], and the beginning of the scene corresponding to the selected number will be searched.

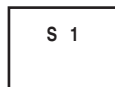

- Up to 9 scene numbers can be selected.

### Continuous Index Search

If the [▶▶] Button or the [◀◀] Button (58) is pressed for 2 seconds or longer, search can be continued at several-second intervals. (To cancel, press the [▶] Button (72) or the [■] Button (70).)

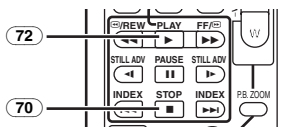

- For other notes concerning this item, see -50-.

### Playback Zoom Function

A part of the image can be enlarged up to 10 times during playback.

- 1 During playback, press the [P.B. ZOOM] Button (74) on the Remote Controller.

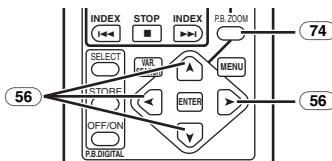

- The center of the image is enlarged to approximately 2 times.



**To Change the Zoom Magnification**

2 Change the magnification by pressing the [W] Button or [T] Button (62) on the Remote Controller.

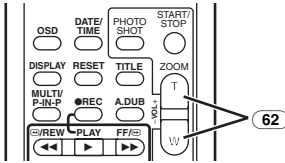

**To Change the Enlarging Area of an Image**

3 Press the Arrow Button (▲, ◀, ▶, ▼) (56) on the Remote Controller that points to the area you want to enlarge.

**To Cancel the Playback Zoom Function**

Press the [P.B. ZOOM] Button (74) on the Remote Controller.

• For other notes concerning this item, see -50-.

**Playback Digital Effect Functions**

During playback, special digital effects can be added to the recorded pictures. The same effects as those of Digital Effects 1 and 2, which are used during recording, are obtained.

1 Press the [▶] Button (72).

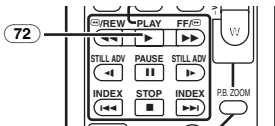

2 Press the [SELECT] Button (59) on the Remote Controller to select a desired digital effect.

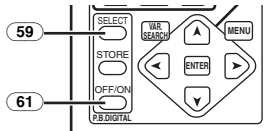

- When the [SELECT] Button is pressed repeatedly, the digital effect selection changes.
- The same setting can be done using [EFFECT SEL] Sub-Menu on the [TAPE PLAYBACK MENU].

**To suspend Playback Digital Effect Temporarily**

Press the [OFF/ON] Button (61) to suspend or restart the digital effect. When the digital effect is paused temporarily, the selected effect's indication flashes.

**To Cancel the Digital Effect**

Press the [SELECT] Button (59) on the Remote Controller and clear the digital effect indication.

**Wipe Mode and Mix Mode**

1 Press the [▶] Button (72).

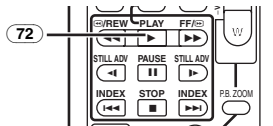

2 Press the [SELECT] Button (59) on the Remote Controller and select [WIPE] or [MIX].

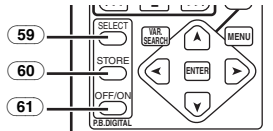

3 Press the [STORE] Button (60) at the moment you want to save as a still picture.

- The [WIPE] or [MIX] Indication appears, and the image is saved.

4 Press the [OFF/ON] Button (61) in the scene in which you want to use the Wipe or Mix effect.

- The scene changes as a result of the Wipe or Mix effect.
- The Wipe Function and Mix Function can only be accessed by using the Remote Controller during playback.
- If the [OFF/ON] Button (61) is pressed while Wipe or Mix is carried out, the effect will stop temporarily at that point. Pressing the [OFF/ON] Button (61) again will bring back the effect.

• For other notes concerning this item, see -50-.

## Playing Back on Your TV

By connecting your Camcorder with your TV, the recorded scenes can be viewed on your TV screen.

- Before connecting them, turn off the power of both the Camcorder and TV.

### 1 Connect the [A/V OUT] Jack of the Camcorder and the Video and Audio Input Jacks of the TV.

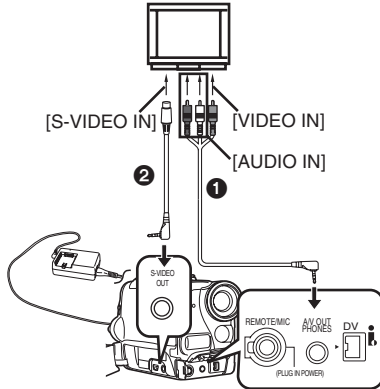

- Connect to the TV with the AV Cable ①. If the TV has an S-Video Jack, connect the S-Video Cable ②, too.
- When plugging the pin plug of the AV cable into the [A/V OUT] Jack, plug it in as far as it goes.

### To Make the Indications Appear on the TV Screen

Press the [OSD] Button (51) on the Remote Controller.

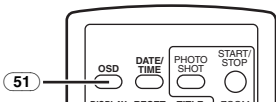

- For other notes concerning this item, see -50-.

## Editing Mode

### Audio Dubbing

You can add music or narration to the recorded Cassette.

- If the tape recorded in the [16bit] Mode is dubbed with the Audio Dubbing function, the original sound is erased. (If you wish to preserve the original sound, use the [12bit] Mode when recording.)
- Audio Dubbing cannot be performed on a recording made in LP Mode. (-20-)

**1 Press the [II] Button (69) on the Remote Controller where you want to add new sound.**

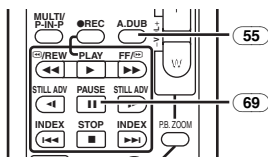

**2 Press the [A.DUB] Button (55) on the Remote Controller.**

**3 To start Audio Dubbing, press the [II] Button (69) on the Remote Controller.**

#### To Cancel Audio Dubbing

Press the [II] Button (69) on the Remote Controller.

The Camcorder is in the Still Playback Mode again.

#### To Play Back the Sound Recorded by 12bit Audio Dubbing

Set [TAPE PLAYBACK MENU] >> [PLAYBACK] >> [12bit AUDIO] >> [ST2] or [MIX].

ST1: It plays back only the original sound.

ST2: It plays back only the sound added by Audio Dubbing.

MIX: It plays back both the original sound and the sound added by Audio Dubbing simultaneously.

#### To Dub Audio While Listening to a Pre-recorded Sound

When pausing the audio dubbing, set the [12bit AUDIO] on the [PLAYBACK] Sub-Menu to [ST2] and you can check the pre-recorded sound. Use headphones to listen to the pre-recorded sound while dubbing the audio.

- For other notes concerning this item, see -50-.

### Copying on an S-VHS (or a VHS) Cassette

#### (Dubbing)

After connecting the Camcorder and the VCR as illustrated, start the following procedures.

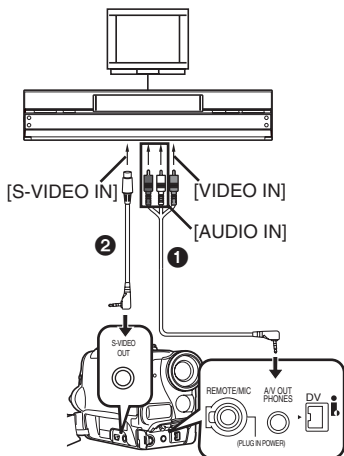

- 1 AV Cable
- 2 S-Video Cable

- Be sure to press the [OSD] Button (-12-) on the Remote Controller prior to copying so that no indications are visible. Otherwise, the displayed tape counter and function indications are also copied.

#### Camcorder:

**1 Insert the recorded Cassette.**

#### VCR:

**2 Insert an unrecorded Cassette with an erasure prevention tab.**

- If various setups (such as external input, tape speed, etc.) are required, please refer to the operating instructions of your VCR.

#### Camcorder:

**3 Press the [▶] Button (11) to start playback.**

#### VCR:

**4 Start recording.**

**5 Press the Pause or Stop Button to stop recording.**

#### Camcorder:

**6 Press the [■] Button (12) to stop playback.**

## Using the DV Cable for Recording

### (Digital Dubbing)

By connecting this Camcorder with other digital video equipment (such as another Camcorder of the same format/model) that has a DV input/output terminal, and using a 4-pin to 4-pin DV Interface cable PV-DDC9 (optional) ❶, high quality images and sounds can be dubbed in the digital mode.

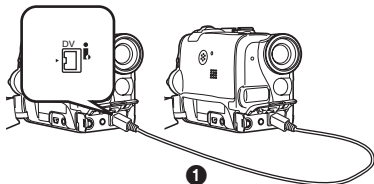

### Player/Recorder:

**1** Insert the Cassette and set to Tape Playback Mode.

### Player:

**2** Press the [▶] Button (72) to start playback.

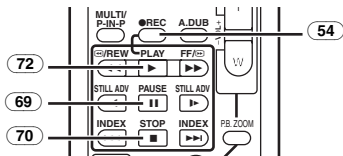

### Recorder:

**3** While pressing the [●REC] Button (54), press the [▶] Button (72).

Or while pressing the [REC] Button (7), press the [BACK LIGHT] Button (8) on the Camcorder.

- Recording starts.

### To Stop Dubbing

Press the [||] Button (69) or the [■] Button (70).

- For other notes concerning this item, see -51-.

### CAUTION:

Unauthorized exchanging and/or copying of copyrighted recordings may be copyright infringement.

## PC Connection With DV Interface Cable

A video clip can be transferred directly to your PC (Personal Computer) via a DV Interface Cable PV-DDC9 (optional) using products and software from a number of video editing software companies.

Using products from video editing software companies allows you to capture and edit video clips using the DV Interface.

**Our DVC being OHCI compliant should have no problem working with any OHCI compliant Firewire Video — Editing software package.**

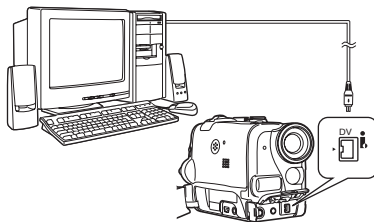

- Personal Computer must be equipped with an DV Terminal.
- During Camcorder playback, do not disconnect the DV Interface Cable or turn the Camcorder off as this may cause a PC hang-up error.
- 1394 (i. LINK) Interface must conform to OHCI (Open Host Controller Interface Specification).

## With a PC (optional)

### Using the Software with a Computer

Following Software is not supplied with the Camcorder;

- LSFT0577 (DV STUDIO 3.1E-SE)
- K1HA05CD0005 (USB Cable)

An image stored on the DV Cassette can be transferred to your Personal Computer. If you would like to order, please refer to page -59-.

#### ■ Software Installation (For Windows)

##### 1 Turn on Personal Computer and start up Windows.

##### 2 Insert the CD-ROM into the Personal Computer's CD-ROM drive.

- The [Setup Menu] screen appears.



##### 3 Select the software to be installed from [Setup Menu].

- **USB Driver -39-:**

This software Driver is for using DV STUDIO.

- **WebCam Driver -40-:**

If the Camcorder is connected to your personal computer to the other parties via the network.

- **DV STUDIO 3.1E-SE (Optional Software) -43-:**

With DV STUDIO 3.1E-SE software, your favorite scene on a tape can be captured to your personal computer as a still image. Also, images viewed through the camera lens can be captured to your personal computer.

- **Acrobat Reader**

To view the installed operating instructions, Adobe Acrobat Reader 5.0 or higher is required. Please install Adobe Acrobat Reader from the CD-ROM (Optional Software).

##### 4 Follow the instructions on the computer screen until the installation is complete.

- Setup window will disappear when the installation is complete.
- If a window does not appear automatically, click the "Start" Button on your desktop and then click "Run". When the "Run" Box is open, type in "D:\InstMenu.exe" and click "OK". ("D" applies when the CD-ROM drive is drive D.)

## Using USB Driver

### ■ Operating environment

- Despite having the operating environment indicated, it may not be possible to use the program with some types of personal computers.
- A CD-ROM drive is required to install this program.

#### OS:

IBM PC/AT compatible personal computer with pre-installed;  
Microsoft Windows XP Home Edition/  
Professional  
Microsoft Windows 2000 Professional  
Microsoft Windows Me (Millennium Edition)  
Microsoft Windows 98 Second Edition

#### CPU:

Intel Pentium II/Celeron 300 MHz or higher (including compatible CPU)

#### RAM:

32 MB or more (64 MB or more recommended) (128 MB or more required for Windows XP)

#### Free hard disk space:

At least 30 MB or more

#### Ports:

USB Terminal

### ■ Installing USB Driver

Please install USB Driver first before connecting the Camcorder to your Personal Computer with the USB Connection Cable.

##### 1 Turn on the Personal Computer and start up Windows.

##### 2 Insert the CD-ROM into the Personal Computer's CD-ROM drive.

- Quit all applications.
- The [Setup Menu] screen appears.

##### 3 Click the [USB Driver].

- The set up program starts running.

##### 4 For Windows 98SE/Me/2000 users, click [Restart] if the [InstallShield] dialog appears.

- Do not remove the CD-ROM.

##### 5 Finish installation by following the on-screen instructions.

- Click [Next] and proceed with installation.
- After completing the installation, Click [Finish].

##### 6 After the USB Driver is installed, please restart your computer.

- Reboot the computer to finish installing USB driver.
- Installation continues after the computer reboots if you selected additional software.

- A message indicating a conflict between versions may be displayed during the installation. This will not cause a problem. Simply click [Yes] to proceed with the installation.
- Depending on the OS version, illustrations and icon names may vary.

**Windows 98SE/Me Users**

The following messages may be displayed when connecting this Camcorder and your personal computer via USB Cable.

**1 For Windows 98SE Users:**

**The message, “Please insert the disk labeled ‘Windows 98 Second Edition CD-ROM’,.....” is displayed. Click [OK].**



- 1) The message “The file ‘kstvtune.ax’ on [Unknown] cannot be found...” is displayed.
    - Enter “C:\Windows\system” for Windows 98SE. Enter “C:\Windows\options\CABS” for Windows Me.
    - If the “kstvtune.ax” file is missing in one of the 2 above-mentioned folders, insert the OS CD-ROM and assign the path.
  - 2) The message “The file ‘ksclockf.ax’ on [Unknown] cannot be found...” is displayed.
    - Enter “C:\Windows\system”.
    - If the “ksclockf.ax” file is missing in the above mentioned folder, insert the OS CD-ROM and assign the path.
- You may click [Browse] to look for and assign the path.

**■ Connecting the Personal Computer and Camcorder**

**Please install the USB Driver first before connecting the Camcorder to your Personal Computer with the USB Cable.**

Before making these connections, turn off all devices which are to be connected.

- When connecting the Personal Computer and Camcorder, use of the AC Adaptor is recommended for the power supply of the Camcorder.

**Using as a Web Camera**

If the Camcorder is connected to your personal computer, you can send video and sound from the Camcorder to the other parties via the network.

- Do not connect the USB Cable until the WebCam is installed.

**This feature can be used only if both parties are using the same operating system. Please see chart below:**

| [Send]               |      | [Receive]            | [Software]        |
|----------------------|------|----------------------|-------------------|
| Windows XP           | ←OK→ | Windows XP           | Windows Messenger |
| Windows XP           | ←NG→ | Windows 98SE/Me/2000 | X                 |
| Windows 98SE/Me/2000 | ←OK→ | Windows 98SE/Me/2000 | MSN Messenger     |

**■ Operating environment**

**OS:**

IBM PC/AT compatible personal computer with preinstalled;  
 Microsoft Windows XP Home Edition/ Professional  
 (In this case of Windows XP SP1 or later is needed.)  
 Microsoft Windows 2000 Professional  
 Microsoft Windows Me (Millennium Edition)  
 Microsoft Windows 98 Second Edition

**CPU:**

Intel Pentium II/Celeron 300 MHz or higher (including compatible CPU)

**RAM:**

32 MB or more (64 MB or more recommended) (128 MB or more required for Windows XP)

**Free hard disk space:**

At least 250 MB or more

**Ports:**

USB Terminal

**To use the Camcorder as a Web Camera, the additional minimum requirements must be met.**

**Graphic display:**

High Color (16 bit) or more  
 Desktop resolution of 800×600 pixels or more

**Communication Speed:**

56 kbps or faster is recommended

**Necessary software:**

Windows Messenger 5.0 or later (Windows XP)  
 MSN Messenger (Windows 98SE/Me/2000)

**Other requirements (to send/receive audio):**

Sound card  
 Speaker or headphones



To use the Camcorder as a Web Camera, the following conditions must be met.

- To upgrade Windows XP to SP1, click [Start] >> [All Programs] >> [Windows Update]. (Requires internet connection.)
- You have direct dial-up connection capability to the Internet. Also, you and the other person(s) are in the same Network (LAN).
- Install the Windows Messenger (Windows XP) or MSN Messenger (Windows 98SE/Me/2000). If you have a version older than 5.0, please download the latest version (5.0 or later) from the Microsoft Home Page.  
<http://www.microsoft.com/>  
<http://www.msn.com/>  
 (For download and installation instructions, please refer to Help on the Home Page.)
- If you are connected to the Internet through a firewall or a router, proper communication will not be possible.
- The installer is available only in English but can be used on operating systems using other languages.
- When DirectX 9.0 is installed, applications supported by previous versions of DirectX may not run.

## ■ Installing WebCam Driver

**1 Turn on the personal computer and start up Windows.**

**2 Insert the CD-ROM into the Personal Computer's CD-ROM drive.**

- Quit all applications.
- The [Setup Menu] screen appears.



**3 Click [WebCam Driver]**

- The set up program starts running.

**4 For Windows XP users:**

**Depending on your system environment, installation of "DirectX 9.0b" may be required. Click [Yes] and continue with installation.**

- After "DirectX 9.0b" is installed, the computer will restart.
- Do not remove the CD-ROM.

**5 Finish installation by following the on-screen instructions.**

- Click [Next] and proceed with installation.
- After completing the installation, Click [Finish].

## ■ Connecting the Camcorder to Personal Computer (For Using as a Web Camera)

**1 Set the Camcorder to Tape Recording Mode.**

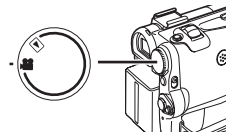

**2 Set [CAMERA] >> [USB FUNCTION] >> [WEB CAMERA].**

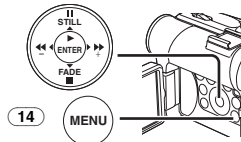

**3 Connect the Camcorder to your Personal Computer with USB Connection Cable.**

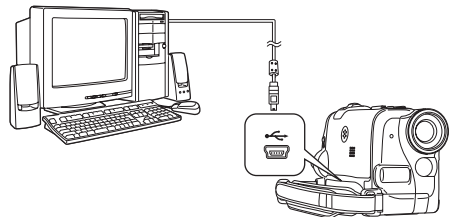

- "WEB" is displayed on the LCD Monitor of the Camcorder.
- When the Camcorder and personal computer (with Windows 2000) are connected via USB Cable, a message, such as the one below, is displayed. However, testing by the manufacturer has confirmed functionality of this Camcorder with Windows 2000. Click [Yes] and proceed.



**• For Windows 98SE/Me users, "USB Audio Device" is required. Click [Next] and proceed.**

• If you use Windows 98SE, the OS installation CD may be required.

**4 Start the Windows Messenger (For Windows XP users) or MSN Messenger (For Windows 98SE/Me/2000 users).**

- Click [Start] >> [All Programs (Programs)] >> [Windows Messenger] or [MSN Messenger].

- When you use Windows XP, the other parties via the network have to use the Windows Messenger on Windows XP. When you use other than Windows XP, the other parties via the network have to use the MSN Messenger on an OS other than Windows XP.
- If the USB Connection Cable is disconnected from the personal computer, the WEB CAMERA mode is cancelled.
- In the Camcorder is used Web Camera, video cannot be recorded onto a tape.

### ■ Setting up the Windows Messenger

When starting the Windows Messenger for the first time, its setup screen is displayed. (However, the screen is not displayed if the Windows Messenger setup has already been done.) For more details, please read the corresponding Help file.

1 Click [Click here to sign in].



2 Select [.NET Messaging Service] and click [OK].

3 Click [Next] when the [.NET Passport Wizard] dialog appears.



4 Please carefully read the displayed contents and then proceed.

5 After the setup is completed, sign in and start the Windows Messenger.



6 Click on [Audio Tuning Wizard...] in the [Tools] menu to confirm that equipment is connected correctly.

7 Select [USB Video Device] in the [Camera] menu.

- When access is finished, close Windows Messenger, then turn off the Camcorder. Finally, disconnect the USB Cable.

### ■ Setting up the MSN Messenger

When starting the MSN Messenger for the first time, its setup screen is displayed. (However, the screen is not displayed if the MSN Messenger setup has already been done.) For more details, please read the corresponding Help file.

1 Click [Sign In].



2 Type in your Sign-in name and password.

- If you do not have your Sign-in name and password, click [Get one here]

3 Please carefully read the displayed contents and then proceed.

4 After the setup is completed, sign in and start the MSN Messenger.



5 Click on [Audio Tuning Wizard...] in the [Tools] menu to confirm that equipment is connected correctly.

6 Click [Web Camera Settings...] in the [Tools] menu.

7 Confirm the [Panasonic DVC Web Camera Device] is selected.

- For other information about MSN Messenger, please refer to Help.
- When access is finished, close MSN Messenger, then turn off the Camcorder. Finally, disconnect the USB Cable.

## Using the DV STUDIO 3.1E-SE (Optional Software)

Following Software is not supplied with the Camcorder;

- LSFT0577 (DV STUDIO 3.1E-SE)
- K1HA05CD0005 (USB Cable)

The Software allows you to capture a still image from your motion video on the tape and transfer to a PC. If you would like to order, please refer to page -59-.

### ■ Operating environment

#### OS:

IBM PC/AT compatible personal computer with pre-installed;  
Microsoft Windows XP Home Edition/  
Professional  
Microsoft Windows Me (Millennium Edition)  
Microsoft Windows 98 Second Edition

#### CPU:

Intel Pentium II/Celeron 300MHz or higher (including compatible CPU)

#### Graphic display:

High Color (16 bit) or more

Desktop resolution of 800×600 pixels or more

#### RAM:

32 MB or more (64 MB or more is recommended) (128 MB or more are required for Windows XP (256 MB or more is recommended))

#### Free hard disk space:

At least 20 MB

#### Ports:

USB Terminal

#### Other requirements:

Mouse

- The DV STUDIO 3.1E-SE cannot be operated on Windows 2000.
- When 2 or more USB devices are connected to a personal computer, or when devices are connected through USB hubs or by using extension cables, proper operation is not guaranteed.
- When connected to the keyboard USB terminal, normal function may not be possible.
- This instruction manual describes only the procedures for installation, connection and startup. Please read the PDF-based instructions for how to use the DV STUDIO 3.1E-SE.
- To view the installed operating instructions, Adobe Acrobat Reader 5.0 or higher is required. Please install Adobe Acrobat Reader from the CD-ROM (Optional Software).
- Before using for the first time, select [Readme] from [Start] >> [All programs (Programs)] >> [Panasonic] >> [DV Studio3], and read any supplementary details or updates.

### ■ Installation of DV STUDIO 3.1E-SE (Optional Software)

- 1 Turn on the personal computer and start up Windows.
- 2 Insert the CD-ROM into the Personal Computer's CD-ROM drive.
  - Quit all applications.
  - The [Setup Menu] screen appears.



- 3 Click [DV STUDIO].

- 4 Click [Next].



- After reading the displayed contents, please carry out the installation according to instructions.

- 5 After the completion of setup, click on [Finish].



- Installation will be completed.
- Sample data is installed concurrently with the DV STUDIO 3.1E-SE software.

## ■ To Use DV STUDIO 3.1E-SE

When using the DV STUDIO 3.1E-SE, use of the AC Adaptor is recommended for the power supply of the Camcorder.

### 1 Set the Camcorder to Tape Recording Mode or Tape Playback Mode.

- To capture images from a tape, set the Camcorder to Tape Playback Mode and insert a tape.
- To capture images viewed through the camera lens, set the Camcorder to Tape Recording Mode.

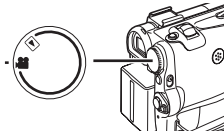

### 2 Set [CAMERA] or [PLAYBACK] >> [USB FUNCTION] >> [DV STUDIO].

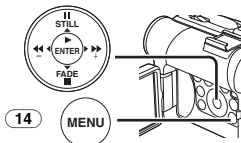

### 3 Connect the Camcorder to your personal computer with USB Connection Cable.

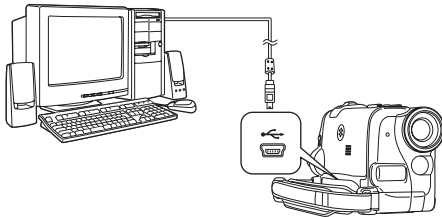

### 4 Select [Start] >> [All Programs (Programs)] >> [Panasonic] >> [DV Studio3] >> [DV Studio3].



- If a shortcut icon has been created on the desktop during installation, it is also possible to start by double-clicking on the icon.
- For other information about DV STUDIO 3.1E-SE Software, please refer to Help.

## If you no longer need Software or Driver (Uninstall)

The screens may vary with the type of the OS.

### 1 Select [Start] (>> [Settings]) >>

[Control Panel], select the software or the driver from [Add/Remove Programs] to **uninstall**.

- Uninstalling steps may vary depending on the OS. Please refer to the user manual of your OS.

### 2 After software or driver is uninstalled, please restart your computer.

## Notes













- Microsoft®, Windows®, Windows Messenger®, MSN Messenger® and DirectX® are either trademarks or the Microsoft Corporation in the United States and/or other countries.
- Intel®, Pentium® and Celeron® are the registered trademarks or trademarks of the Intel Corporation.
- All other names, company names, product names, etc. in these instructions are the trademarks or registered trademarks of their respective corporations.
- The names of the products you are using may differ from the names given in the text. Depending on the operating environment and other factors, the contents of the screens used in these instructions may not necessarily match what you will see on your screen.
- Although the screens in these Operating Instructions are shown in English for the sake of example, other languages are supported as well.
- These instructions do not cover the basic operations of the personal computer or define any terms. For this information, refer to the Operating Instructions which accompany your personal computer.
- Do not disconnect USB Connection Cable while the operation light of Camcorder is on. It may freeze the software or destroy the data in transfer.
- If the Camcorder is used as a Web Camera while virus checking software is running, the Camcorder's operation may stop midway through. In this case, exit the Windows Messenger or MSN Messenger, reconnect the Camcorder and restart the Windows Messenger or MSN Messenger.
- When you are using Windows XP or Windows 2000, you may install or uninstall this software after logging ON by setting the user name to Administrator or to a user name having equivalent authority.



















- If you install the USB Driver after the USB Cable is connected, or if you do not follow these Operating Instructions, the Camcorder will not be recognized correctly. In this case, delete the USB Driver from [Device Manager] as described below, uninstall the USB Driver, and re-install it.
  - With the Camcorder and personal computer connected via a USB Cable, open the [Device Manager]. Right-click [!DVC] in [Ports] or [Other devices], and select [Uninstall]. (!DVC) will differ depending on the OS or operating environment of your personal computer.)

## Others

### Indications

Various functions and the Camcorder status are shown on the screen.

|  |  |
|--|--|
|    | Remaining Battery Power  |
| •  | When the battery power becomes low, the Indication changes. When the battery is discharged completely, the  (  ) Indication flashes. |
| RO:45:   | Remaining Tape Time  |
| •  | Remaining tape time is indicated in minutes. (When it reaches less than 3 minutes, the indication starts flashing.)  |
|    | Tape Recording Mode -21-   |
|    | Tape Playback Mode -32-  |
| CINEMA:  | Cinema Mode -27-   |
| D.ZOOM:  | Digital Zoom -24-  |
| MULTI:   | Multi Mode -30-  |
| P-IN-P:  | P-IN-P Mode -30-   |
| WIPE:  | Wipe Mode -30-   |
| MIX:   | Mix Mode -30-  |
| STROBE:  | Strobe Mode -30-   |
| TRAIL:   | Trailing Effect Mode -30-  |
| MOSAIC:  | Mosaic Mode -30-   |
| MIRROR:  | Mirror Mode -30-   |
| STRETCH:   | Stretch Mode -30-  |
| SLIM:  | Slim Mode -30-   |
| NEGA:  | Negative Mode -30-   |
| SEPIA:   | Sepia Mode -30-  |
| B/W:   | Black & White Mode -30-  |
| SOLARI:  | Solarisation Mode -30-   |
| (PB) ZOOM:   | Playback Zoom -34-   |
| SP:  | Standard Play Mode (Recording Speed Mode) -20-   |
| LP:  | Long Play Mode (Recording Speed Mode) -20-   |
| INDEX:   | Index signal recording -34-  |
| S 1:   | Search Number -34-   |
| 5X:  | Zoom Magnification Indication -23-   |
| AUTO:  | Automatic Mode -21-  |
| MNL:   | Manual Mode -27-   |
| EIS:   | Image Stabilizer -24-  |
| 12 bit, 16 bit:  | Audio Recording Mode -20-  |
| MF:  | Manual Focus -29-  |
|  | Back Light Mode -25-   |
|  | Sports Mode (Program AE) -27-  |
|  | Portrait Mode (Program AE) -27-  |
|  | Low Light Mode (Program AE) -27-   |
|  | Spotlight Mode (Program AE) -27-   |
|  | Surf & Snow Mode (Program AE) -27-   |
| REC:   | Recording -21-   |
| PAUSE:   | Recording Pause -21-   |
|  | Self-Timer Recording -23-  |

|   |  |
|---|--|
|         | When connecting the Magic Wire Remote Control with Narration Mic (optional) to [REMOTE] Jack and the [TALK] Button is pressed, this indication appears. -22- |
|        | Playback -32-  |
|        | Still Playback -33-  |
|        | Fast-forward/Cue Playback -32-   |
|        | Rewind/Review Playback -32-  |
|        | Slow Motion Playback -33-  |
|        | Still Advance Playback -33-  |
|        | Index Search -34-  |
| CHK:  | Recording Check -21-   |
| A.DUB  | Audio Dubbing -37-   |
| A.DUB  | Audio Dubbing Pause -37-   |
| BLANK:  | Blank Search -22-  |
| R      | Repeat Playback -50-   |
| 2x     | Variable Speed Search -33-   |
| 1/500:  | When you adjust shutter speed manually, this indication appears. -29-  |
| F2.0:   | When you adjust the F Number manually, this indication appears. -29-   |
|        | White Balance Adjustment Mode -28-   |
|        | Outdoor Mode -28-  |
|        | Indoor Mode (recording under incandescent lamp) -28-   |
| MAGICPIX:   | MagicPix Function -26-   |
| 0LUX MAGICPIX:  | 0 Lux MagicPix Function -26-   |
| Z.MIC:  | Zoom Microphone -24-   |
| WIND CUT:   | Wind Noise Reduction -26-  |
|        | Progressive Photoshot Mode -22-  |
|      | Tele Macro -24-  |
|      | Soft Skin Mode -26-  |
| VOLUME:   | Volume adjustment -32-   |
| 3:30:45PM:  | Date/Time Indication -47-  |

### ■ To Change the Counter Display Mode

By changing [C.DISPLAY] on the [DISPLAY] Sub-Menu, you can change the Counter Display Mode to Tape Counter Indication [COUNTER] (0:00.00), Memory Counter Indication [MEMORY] (M0:00.00), and Time Code Indication [TIMECODE] (0h00m00s00f). (-18-) By repeatedly pressing the [DISPLAY] Button on the Remote Controller, you can change the Counter Display Mode.

## ■ To Display Date/Time Indication

To display Date/Time Indication, set the appropriate Date/Time in [DATE/TIME] on the [DISPLAY] Sub-Menu. (-18-)

You can also press the [DATE/TIME] Button of the Remote Controller repeatedly to display or change the Date/Time Indication.

## ■ To Change the Display Mode

By changing [DISPLAY] on the [DISPLAY] Sub-Menu, you can change the Display Mode to All Function Display [ALL] and Minimum Display [OFF]. (-18-)

## ■ Progressive Photoshot

You cannot use the Progressive Photoshot Function in the following cases.

- Digital Effect Modes in [EFFECT1]
- Digital Zoom [D.ZOOM]
- 1/750 s or faster shutter speed
- When brightness is insufficient
- When the MagicPix Function is ON
- When the Portrait Mode is used

## Initializing the Modes

You can change the Menu settings back to the shipping condition.

### 1 Set [INITIAL] >> [INITIAL SET] >> [YES].

- The initializing takes for a little while.
- After the initializing is completed, the [COMPLETED] Indication appears.
- Initializing will not erase the clock setting (-20-) that has been adjusted.

## Warning/Alarm Indications

If any one of the following indications lights up or flashes, please check the condition of the Camcorder.

### DEW (DEW DETECT/EJECT TAPE):

Condensation has occurred. -52-

### (CHECK REC TAB):

The accidental erasure prevention switch on the inserted Cassette is open (that is, set to [SAVE]).

You are attempting Audio dubbing or Digital dubbing on a Tape while setting the accidental erasure prevention switch to [SAVE].

### (TAPE NOT INSERTED):

No Cassette is inserted. -16-

### (LOW BATTERY):

The Battery is low. Recharge it. -14-

### : The built-in battery is low. -20-

### (NEED HEAD CLEANING):

The video heads are dirty. -53-

### END (TAPE END):

The tape came to end during recording.

### REMOTE (CHECK REMOTE MODE):

Wrong Remote Controller Mode has been selected. -13-

### UNPLAYABLE TAPE

#### (OTHER FORMAT):

You are attempting to play back a tape section that has been recorded with a different TV system.

### UNABLE TO A.DUB

#### (LP RECORDED):

Because the original recording was done in LP Mode, audio dubbing cannot be performed.

### INCOMPATIBLE TAPE:

This cassette is incompatible.

### PUSH THE RESET SWITCH:

Irregular mechanism is detected. Press the [RESET] Button (-11-). This may solve the problem.

### COPY INHIBITED:

Because the medium is protected by a copy guard, images cannot be recorded correctly.

### CASSETTE DOOR OPEN:

Close the Cassette Compartment Cover before recording.

## Notes and Hints

### ■ Concerning the Power Supply

- When the Camcorder is used for a long time, the Camera body becomes warm, but this is not a malfunction.
- If the [CHARGE] Lamp does not light up although the Battery is attached to the AC Adaptor, detach the Battery and reattach it.

### ■ Inserting/Removing the Cassette

- In the case of using a previously recorded Cassette, you can use the Blank Search Function to find the position where you want to continue recording.
- If a new Cassette is inserted, rewind to the beginning of the tape before starting recording.
- When inserting the cassette, make sure it faces in the right direction and then push it in until it stops.
- When the Cassette Holder is in action, do not touch anything except the [PUSH] Button.
- When closing the Cassette Compartment Cover, do not get anything caught in the cover, such as a cable of an optional stereo microphone.

## ■ Alarm Sounds

When [BEEP SOUND] on the [INITIAL] Sub-Menu on the [TAPE RECORDING MENU] is set to [ON], confirmation/alarm beeps are issued as follows.

1 Beep

- When you start recording
- When you switch the [OFF/ON] Switch from [OFF] to [ON]

2 Beeps

- When you pause recording
- 2 Beeps for 4 times
- If you operate a wrong operation before or during recording.

## ■ Recording Check

- For Recording Check, the recording speed mode (SP/LP) must be the same as the mode used for the recording. If different, playback images will be distorted.

## ■ Quick Start

- During the Quick Start Standby Mode, a minute amount of electricity is consumed.
- When the Camcorder is left in the Recording Pause Mode for 5 minutes, it will be turned into the Quick Start Standby Mode. To turn the Camcorder on again, set the [OFF/ON] Switch to [OFF] and then set it to [ON] again. (The Quick Start Mode will be restored.)
- This Function is not activated when a tape is not inserted even if the Quick Start Recording Lamp lights.
- In the following cases, Quick Start is cancelled during the Quick Start Standby Mode.
  - Operate the mode dial
  - The Battery is replaced
- If the [QUICK START] Button is pressed and held for approximately 2 seconds during the Quick Start Standby Mode, the Lamp will go off and the Camcorder will completely be turned off.
- If the Camcorder is not operated for approximately 30 minutes when the Quick Start Recording Lamp lights, the Lamp will go off and the Camcorder will completely be turned off.
- In the Automatic White Balance Mode, the color may be recorded unnaturally at the beginning of the recording.
- The zoom magnification differs from when it is in the Quick Start Standby Mode and when the recording starts.

## ■ Photoshot

- Photoshot Recording results in slightly inferior image quality.

## ■ Self-timer Recording

- When [BEEP SOUND] on the [INITIAL] Sub-Menu is set to [ON], the beep sound will be emitted along with the Recording Lamp flashing in the Self-timer Standby Mode.
- By operating the [OFF/ON] Switch, Recording Start/Stop Button or Mode Dial, the Self-timer Standby Mode is cancelled.

## ■ Zoom In/Out Functions

- When you are zooming on a faraway subject, a sharper focus is achieved if the recording subject is 4 feet (1.2 meters) or further from the Camcorder.

## ■ Tele-Macro Function

- The Tele-Macro Function cannot be started during recording.
- When the [D.ZOOM] is set to [25×] or [700×], the Tele-Macro Function with the magnification greater than 10× is available.
- If a sharper focus cannot be achieved, adjust the focus manually.

**In the following cases, the Tele-Macro Function is cancelled.**

- The zoom magnification becomes lower than 10×.
- Setting the [OFF/ON] Switch to [OFF].

## ■ Zoom Microphone Function

- The Zoom Microphone Function may not work effectively if the surrounding noise is too loud.
- It does not work with an external microphone.

## ■ Digital Zoom Functions

- As the magnification of digital zoom increases, the quality of image may deteriorate.
- White balance cannot be set in the digital zoom range.

## ■ Image Stabilizer Function

- The Image Stabilizer Function does not operate in a dimly lit place. In this case, the [EIS] Indication flashes.
- Under fluorescent lighting, image brightness may change or colors may not look natural.
- After-images may appear.
- When a tripod is used, it is recommended that you turn the Image Stabilizer off.
- Within the digital zoom range, or when recording with a conversion lens attached, the Image Stabilizer Function may not work effectively.

## ■ Backlight Compensation Function

- When setting the Iris manually, the Backlight Compensation Function does not work.
- By operating the [OFF/ON] Switch, the Backlight Compensation Function is cancelled.



## ■ MagicPix Functions

- In a bright place, such as outdoors, the recorded picture may become whitish.
- In a dark place, the recorded picture is presented in a time-lapse-like manner.
- Adjust the Focus manually.
- The Progressive Photoshot Function is automatically turned off.
- White Balance cannot be set.
- The shutter speed cannot be adjusted.
- The Image Stabilizer, Program AE or Digital Effect Modes in [EFFECT1] cannot be set.
- When recording with the MagicPix Function, it is recommended that you use the tripod.
- The MagicPix Function makes the signal charging time of CCD longer up to 30 times longer than usual, so that the dark scenes that are invisible to the naked eyes can be recorded brightly. For this reason, a bright dots may be seen, but this is not a malfunction.
- The Image Stabilizer Function does not work. In this case, the [EIS] Indication flashes.
- The Soft Skin Function and the Backlight Compensation Function cannot be changed.

## ■ Wind Noise Reduction Function

- It does not work with the microphone on the Magic Wire Remote Control with Narration Mic (optional) nor an external microphone.
- When it is set to [ON], directivity of microphone is regulated depending on the strength of wind to reduce wind noise.

## ■ Cinema Function

- Using the Cinema Mode does not widen the recording angle.
- If you play back tape recorded in Cinema Mode on a wide-screen (16:9) format TV, playback size is automatically adjusted to fit the TV screen format. Please refer to the TV's operating instructions for details.
- When images are displayed on a TV screen, the Date/Time Indication may be erased in some cases.
- Depending on the TV, the picture quality may be deteriorated.
- Using the Cinema Mode deactivates [MULTI] and [P-IN-P] of [EFFECT1].
- Depending on the software in use, the imported Cinema picture may not be displayed correctly.

## ■ Program AE

- If any of the Program AE Modes are selected, you cannot adjust the shutter speed (-29-) or iris (-29-).
- Using the MagicPix Function cancels any of the Program AE modes.

## Sports Mode

- During normal playback, the image movement may not look smooth.
- Because the color and brightness of the playback image may change, avoid recording under fluorescent light, mercury light or sodium light.
- If you record a subject illuminated with strong light or a highly reflective subject, vertical lines of light may appear.
- If the light is insufficient, the [  ] Indication flashes.

## Sports Mode/Portrait Mode

- If you record a still picture in Progressive Photoshot Mode, the brightness and hue of the recorded still picture may become unstable.
- If this mode is used for indoor recording, playback images may flicker.

## Low Light Mode

- Extremely dark scenes may not be able to be made brighter to a satisfactory degree.

## Spotlight Mode

- With this mode, recorded images may become extremely dark.
- If the subject is extremely bright, its recorded image may become whitish.

## Surf & Snow Mode

- If the subject is extremely bright, its recorded image may turn out to be whitish.

## ■ White Balance

In the following cases, you cannot change White Balance:

- When you set [EFFECT2] to [SEPIA] or to [B/W].
- When you set the Zoom to 10× or higher
- During Digital Still Picture Mode
- When you display a Menu
- When you use the MagicPix Mode

In the following cases, the [  ] Indication flashes:

- The flashing indicates that the previously adjusted White Balance setting is still kept. This setting will be kept until White Balance is adjusted again.
- You may not be able to achieve correct White Balance Adjustment manually under weak illumination.

## ■ Manual Shutter Speed Adjustment

- You may see vertical lines of light in the playback image of a brightly shining subject or highly reflective subject.
- During normal playback, movement in the images may not look smooth.

- Because the color and brightness of the playback image may become unstable, avoid recording under fluorescent light, mercury light or sodium light.
- If you are using MagicPix Mode (-26-) or Program AE Mode (-27-), you cannot adjust the shutter speed.

### ■ Manual Iris Adjustment

- Depending on zoom magnification, there are iris values that will not be displayed.
- If you are using MagicPix Mode (-26-) or Program AE Mode (-27-), you cannot adjust the iris.
- If you attempt to adjust the Shutter Speed after setting the Iris, the value set for the Iris will be cancelled.

### ■ Digital Effect Functions

- If you have set [EFFECT2] to [B/W] or [SEPIA], changing the selected White Balance Mode is not possible. (-27-)
- Setting the Cinema Mode cancels the Picture-in-Picture Mode and the Multi-Picture Mode.
- During the Digital Still Picture Mode, the Digital Effect Functions cannot be set.

**In the following cases, using the [EFFECT1] on the [DIGITAL] Sub-Menu is not possible.**

- When the MagicPix Mode is set (-26-)

#### Multi-Picture Mode

- If the [MULTI] Button is pressed while self-recording Mirror Mode (-23-) is used, the still picture is displayed from the upper right corner of the screen, but, in reality, the picture is recorded from the upper left corner as usual.
- The quality of Multi images deteriorates slightly.
- The top and bottom of the Multi pictures will be cut off slightly.

#### Picture-in-Picture Mode

- If Mode Dial is operated, the smaller picture disappears.

#### Wipe Mode and Mix Mode

If one of the following operations are carried out, stored images will be erased, and Wipe and Mix Functions cannot be used.

- Set another Digital Effect item.
- Operate the [OFF/ON] switch or Mode Dial
- Insert or eject a cassette

### ■ Playing Back

#### Repeat Playback

If you continue to press the [▶] Button for 5 seconds or longer, the Camcorder switches to Repeat Playback Mode, and the [R ▷] Indication appears. (To cancel Repeat Playback Mode, set the [OFF/ON] Switch to [OFF].)

### Choosing Sound during Playback

You can select the sound by using the [AUDIO OUT] setting on the [PLAYBACK] Sub-Menu.

STEREO: Stereo Sound (main sound and sub sound)

L: Left channel sound (main sound)

R: Right channel sound (sub sound)

- If you dub a tape recorded at the [12bit] selected as the [AUDIO REC] on the [RECORDING] Sub-Menu, playback sound becomes stereo sound regardless of the [AUDIO OUT] setting if [12bit AUDIO] is set to [MIX].

### ■ Index Search Functions

- Index Search may not be possible at the beginning of the tape.
- Scene Index Search may not function properly if the interval between 2 scene index signals is less than 1 minute.

### ■ Playback Zoom Function

- You cannot adjust the sound volume with the Remote Controller in Playback Zoom Mode.
- If you turn off the Camcorder power or if you operate the Mode Dial, Playback Zoom Mode is automatically cancelled.
- Even if Playback Zoom Functions are being used, images that are output from the DV Terminal (-11-) are not enlarged.
- As you enlarge an image, the quality of the image deteriorates.
- During a Playback Zoom, the Variable Speed Search Function cannot be changed with the Remote Controller.

### ■ Playback Digital Effect Functions

- Signals of images to which digital effects are added during playback cannot be output from the DV Terminal (-11-).
- You cannot use the Wipe or Mix Function while playing back the non-recorded portion of tape.

### ■ Playing Back on Your TV

- Depending on your TV, nothing may be shown even if you correctly connect the Camcorder with your TV. In this case, set [AV JACK] on the [INITIAL] Sub-Menu to [OUT].
- Picture size may be displayed differently when playing back a Cinema picture on a wide-screen TV with Playback Digital Effect.

### ■ Audio Dubbing

- The blank section of a tape cannot be dubbed.
- Sounds sent through the DV Terminal cannot be dubbed.

- If a tape has a non-recorded portion when the tape is dubbed, images and sounds may be disturbed when this portion of the tape is played back.
- If you set the tape counter back to 0 at the position where you want to stop Audio Dubbing so as to make it possible to use the Memory Stop Function (-57-), Audio Dubbing is terminated automatically when the tape reaches this position.
- In the case of importing data recorded with Audio Dubbing to a PC using the PC's software, only the original sound (ST1) may be imported, depending on the software.

### ■ Using the DV Cable for Recording (Digital Dubbing)

- Regardless of the setting, digital dubbing is carried out automatically in the same audio recording mode as that of the playback Cassette.
- The images on the recorded monitor may be disturbed, but it does not affect the recorded images.
- Even if Playback Digital Effects or Playback Zoom have been used, these effects are not output from the DV Terminal.
- Even if you use a device equipped with DV Terminals, you may not be able to perform Digital Dubbing in some cases.
- Date or other information to be displayed cannot be displayed if the software of the connected equipment does not support the display function.
- Disconnect the USB Cable (optional) since input signals from external input terminal cannot be recorded with connecting the USB Cable.

## Cautions for Use

### ■ After Use

- 1 Take out the Cassette. (-16-)
- 2 Set the [OFF/ON] Switch to [OFF].
- 3 Detach the power supply and retract the Viewfinder or the LCD Monitor. (-14-, -17-)
- 4 To protect the Lens, attach the supplied Lens Cap.

### ■ Cautions for Use

**When you use your Camcorder on a rainy or snowy day or on a beach, make sure that no water enters the Camcorder.**

- Water may cause the Camcorder or Cassette to malfunction. (Irreparable failure may occur.)
- If sea water splashes onto the Camcorder, wet a soft cloth with tap water, wring it well, and use it to wipe the camera body carefully. Then, wipe it again thoroughly with a soft dry cloth.

**Keep the Camcorder away from magnetized equipment (such as a microwave oven, TV, video game equipment, etc.).**

- If you use the Camcorder on or near a TV, images or sounds may be disturbed due to electromagnetic wave radiation.
- Do not use near a cell phone because doing so may cause noise to adversely affect the picture and sound.
- Recordings on the tape may be damaged, or images may be distorted, by strong magnetic fields created by speakers or large motors.
- Electromagnetic wave radiation generated by a microprocessor may adversely affect the Camcorder, causing the disturbance of images and sounds.
- If the Camcorder is affected by magnetically charged equipment and does not function properly, turn off the Camcorder power and detach the Battery or AC Adaptor and then connect the Battery or AC Adaptor again. Thereafter, turn on the Camcorder power.

**Do not use your Camcorder near radio transmitters or high-voltage cables.**

- If you record pictures near radio transmitters or high-voltage cables, recorded images or sounds may be adversely affected.

**Do not use this Camcorder for surveillance purposes or other business use.**

- If you use the Camcorder for a long period of time, the internal temperature increases and, consequently, this may cause malfunction.
- This Camcorder is not intended for business use.

**When you use your Camcorder on a beach or similar place, do not let sand or fine dust get into the Camcorder.**

- Sand or dust may damage the Camcorder or Cassette. (Care should be taken when inserting and removing the Cassette.)

**Do not spray insecticides or volatile chemicals onto the Camcorder.**

- If the Camcorder is sprayed with such chemicals, the camera body may be deformed and the surface finish may peel off.
- Do not keep rubber or plastic products in contact with the Camcorder for a long period of time.

**Do not use benzine, thinner or alcohol for cleaning the Camcorder.**

- The Camcorder body may be deformed and the surface finish may peel off.
- Before cleaning, detach the Battery or pull out the AC Cable from the AC Jack.
- Wipe the Camcorder with a soft dry cloth. To remove stubborn stains, wipe with a cloth that is soaked in a detergent diluted with water and afterwards finish wiping with a dry cloth.
- For storing or transporting the Camcorder, place it in a bag or case lined with soft pads so as to prevent the coating on the camera body from being worn.

**After use, be sure to take the Cassette out and detach the Battery from the Camcorder or pull out the AC Cable from AC Jack.**

- If the Cassette is left in the Camcorder, the tape sags and deteriorates.
- If the Battery is left on the Camcorder for a long time, the voltage drops excessively, and the Battery will not function even after it is recharged.

### ■ About AC Adaptor

- If the temperature of the Battery is extremely high or extremely low, the [CHARGE] Lamp may continue flashing, and the Battery may not be charged. After the temperature of the Battery has decreased or increased sufficiently, charging starts automatically. If the [CHARGE] Lamp continues to flash even after the Battery temperature has decreased or increased sufficiently, the Battery or AC Adaptor may be faulty. In this case, please contact a dealer.
- If the Battery is warm, charging takes a longer time than normal.
- If you use the AC Adaptor near a radio, radio reception may be disturbed. Keep the AC Adaptor 3 feet (1 meter) or more away from radio.
- When using the AC Adaptor, it may generate whirring sounds. However, this is normal.

- After use, be sure to pull out the AC Cable from the AC jack. (If they are left connected, a minute amount of current is consumed.)
- Keep the electrodes of the AC Adaptor and Battery always clean.

### ■ Condensation

If you turn the Camcorder on when condensation occurs on the head or the tape, Condensation Indication [  DEW ] (yellow or red) blinks on the Viewfinder or the LCD monitor and the messages [DEW DETECT] or [EJECT TAPE] (only when the tape is inserted) appear. In this case, follow the procedure below.

#### **Blinking in yellow:**

Dew is slightly adhering on the head or the tape.

#### **Blinking in red:**

Dew is adhering on the head or the tape.

#### **1 Remove the tape if it is inserted.**

- It takes about 20 seconds to open the Cassette Holder. This is not a malfunction.

#### **2 Leave the Camcorder with the Cassette Compartment Cover closed to cool or warm it to the ambient temperature.**

#### **When [ DEW ] blinks in yellow**

- Leave the Camcorder for about 30 minutes.

#### **When [ DEW ] blinks in red**

- The Power Indicator Lamp blinks for about 1 minute and then the Camcorder automatically turns off. Leave it for about 2 to 3 hours.

#### **3 Turn the Camcorder on again, set it to the Tape Recording/Playback Mode and then check if the condensation indication disappears.**

Especially in cold conditions, dew may be frozen. In this case, it may take more time before the condensation indication disappears.

#### **Watch for Condensation even before the Condensation Indication is displayed.**

- The condensation indication may not appear depending on circumstances. When condensation occurs on the lens or the Camcorder, it also may occur on the head and the tape. Do not open the Cassette Compartment Cover.

#### **When the Lens Is Fogged:**

Set the [OFF/ON] Switch to [OFF] and leave the Camcorder in this condition for about 1 hour.

When the lens temperature becomes close to the ambient temperature, the fog disappears naturally.

## ■ Video Head Clogging and Care

If the heads (the parts that make contact with the tape) are dirty, mosaic-pattern noise may appear on the playback image, or the screen as a whole becomes black. If the heads are extremely dirty, recording performance deteriorates, and, in the worst case, the Camcorder cannot record at all.

### Causes of Dirty Heads

- Large quantity of dust in the air
- High-temperature and high-humidity environment
- Damaged tape
- Long operating hours

### Using Mini-DV Format Digital Video Head Cleaner

- 1 Insert the Head Cleaner into the Camcorder in the same manner as a Video Cassette.**
- 2 Press the [▶] Button, and approximately 20 seconds later, press the [■] Button. (Do not rewind the tape.)**
- 3 Take out the Head Cleaner. Insert a Video Cassette and start recording. Then, play the tape back to check the recorded image.**
- 4 If the image is not still clear, repeat Steps 1 to 3. (Do not use the Head Cleaner for 3 times or more consecutively.)**

### Notes:

- Do not rewind every time you use the Head Cleaner. Rewind only when the tape reaches the end, and then use it again from the beginning in the same manner as before.
- If the heads become dirty soon after cleaning, the tape may be damaged. In this case, immediately stop using that Cassette.
- Do not clean the heads excessively. (Excessive cleaning may cause excessive wear of the heads. If the heads are worn, images cannot be played back even after the heads are cleaned.)
- If the dirty heads cannot be cleaned with the Head Cleaner, the Camcorder needs to be cleaned at a service center. Please consult a dealer.
- Video Head Cleaners can be purchased from service centres.
- Head cleaning due to dirty heads is not considered a malfunction of the product. It is not covered by the warranty.

### Periodical Check-up

To maintain the highest image quality, we recommend replacement of worn parts, such as heads, etc., after approximately 1000 hours of use. (This, however, depends on operating conditions, such as temperature, humidity, dust, etc.)

## ■ Optimal Use of the Battery Battery Characteristics

This Battery is a rechargeable lithium ion battery. Its ability to generate power is based upon the chemical reaction that takes place inside it. This reaction is susceptible to the surrounding temperature and humidity, and, if the temperature is too high or too low, the operating time of the Battery becomes shorter. If the Battery is used in an extremely cold environment, the Battery may operate only for about 5 minutes. If the Battery becomes extremely hot, a protective function may operate, and the Battery may become unusable for a while.

### Be Sure to Detach the Battery after Use

Be sure to detach the Battery from the Camcorder. (If it is left attached to the Camcorder, a minute amount of current is consumed even when the Camcorder power is off.) If the Battery is left attached to the Camcorder for a long time, over-discharge takes place. The Battery may become unusable after it is charged.

### Disposing of an Unusable Battery

- The Battery has a limited life.
- Do not throw the Battery into fire because it may cause an explosion.

### Always Keep the Terminals of the Battery Clean

Prevent the terminals from getting clogged with dirt, dust, or other substances.

If you drop the Battery accidentally, check to see if the Battery body and terminals are deformed. Attaching a deformed Battery to the Camcorder or AC Adaptor may damage the Camcorder or AC Adaptor.

## ■ Cautions for Storage

### Before storing the Camcorder, take the Cassette out and detach the Battery.

Store all the components in a dry place with a relatively stable temperature.

Recommended Temperature: 59°F to 77°F (15°C to 25°C), Recommended Humidity: 40% to 60%

### Camcorder

- Wrap it with a soft cloth to prevent dust from getting into the Camera.
- Do not leave the Camcorder in places that expose it to high temperature.

## Battery

- Extremely high temperatures or low temperatures will shorten the life of the Battery.
- If the Battery is kept in smoky or dusty places, the terminals may rust and cause malfunctions.
- **Do not allow the Battery terminals to come in contact with metal objects (such as necklaces, hairpins, etc.). This can result in a short circuit or heat generation and, if you touch the Battery in this condition, you may be badly burned.**
- Store the Battery in a completely discharged state. To store the Battery for a long period of time, we recommend you charge it once every year and store it again after you completely use up the charged capacity.

## Cassette

- Before storing it, rewind the tape to the beginning. If the Cassette is left for more than 6 months with the tape stopped midway, the tape sags (although it depends on the storage condition). Be sure to rewind to the beginning.
- Store the Cassette in its case. Dust, direct sunlight (ultraviolet rays), or humidity may damage the tape. Dust contains hard mineral particles, and dusty Cassettes damage the heads of the Camcorder and other components. Develop a habit of returning the Cassette back to its case.
- Once every half year, wind the tape to the end and then rewind it to the beginning. If the Cassette is left for 1 year or longer without winding or rewinding, temperature and humidity changes may cause the Cassette to deform due to swelling, shrinking, and so forth. The wound tape may stick to itself.
- Do not place a Cassette near highly magnetic substances or equipment.
- The surface of tape is covered with extremely minute magnetic particles, upon which signals are recorded. Magnetic necklaces, toys, etc., have magnetic force that is stronger than you may normally expect, and they may erase the contents of a recording or may cause noise in images and sounds.

## ■ LCD Monitor/Viewfinder/Lens Hood LCD Monitor

- In a place with drastic temperature changes, condensation may form on the LCD Monitor. Wipe it with soft dry cloth.
- If your Camcorder is extremely cold when you turn its power on, the image on the LCD Monitor is slightly darker than usual at first. However, as the internal temperature increases, it goes back to the normal brightness.

Extremely high precision technology is employed to produce the LCD Monitor screen featuring a total of approximately 123,000 pixels. The result is more than 99.99% effective pixels with a mere 0.01% of the pixels inactive or always lit. However, this is not a malfunction and does not affect the recorded picture.

## Viewfinder

- Do not direct the Viewfinder or Lens to the sun. Internal components may be seriously damaged.
- When the Camcorder is used with a large capacity Battery (CGA-DU14, CGA-DU21: optional) attached to it, it is not practical to look in the Viewfinder from behind the Battery.

Extremely high precision technology is employed to produce the Viewfinder screen featuring a total of approximately 113,000 pixels. The result is more than 99.99% effective pixels with a mere 0.01% of the pixels inactive or always lit. However, this is not a malfunction and does not affect the recorded picture.

## Lens Hood

- Do not attach other conversion lenses in front of the Lens Hood; there is no mount to be used for the attachment.
- When you wish to attach the Tele Conversion Lens (not supplied), Wide Conversion Lens (not supplied), MC Protector (not supplied), or ND Filter (not supplied), first of all, turn the Lens Hood counter-clockwise. If the MC Protector or ND Filter is used, the Lens Hood can be mounted on the filter.
- If you push the [W/T] Lever toward [W] during recording with the filter and conversion lens attached together to the Camcorder, 4 corners of the image may become dark (vignetting). For details, please refer to the operating instructions of your accessories.
- Be sure to keep the Lens Hood attached to the Camcorder so as to shut out unnecessary light.

## **Before Requesting Service (Problems and Solutions)**

### **Power**

#### **1: The Camcorder power cannot be turned on.**

- Is the power source connected correctly? (-14-)

#### **2: The Camcorder power is turned off automatically.**

- When the Recording Pause Mode continues for more than 5 minutes, the power is turned off automatically for tape protection and power conservation. (If the AC Adaptor is used, the power is turned off only when the tape is inserted in Tape Recording Mode.) When the tape is inserted in Tape Recording Mode and if the Recording Pause Mode continues for more than 5 minutes the power is turned off automatically. To resume recording from this condition, turn off, then turn on the power again.

#### **3: The Camcorder power does not stay on long enough.**

- Is the Battery low? Charge the Battery or attach a fully charged Battery. (-14-)
- Has condensation occurred? Wait until the Condensation Indication disappears. (-52-)

### **Battery**

#### **1: Battery runs down quickly.**

- Is the Battery fully charged? Charge it with the AC Adaptor. (-14-)
- Are you using the Battery in an extremely cold place? In cold places, the operating time of the Battery becomes shorter. (-53-)
- Has the Battery worn out? If the operating time is still too short even after the Battery is fully charged, the Battery has worn out.

#### **2: The Battery cannot be charged.**

- If the DC Cable is connected to the AC Adaptor, charging cannot be performed. Disconnect the DC Cable.

### **Normal Recording**

#### **1: Recording does not start although power is supplied to the Camcorder and the Cassette is correctly inserted.**

- Is the accidental erasure prevention slider on the Cassette open? If it is open (set to [SAVE]), recording cannot be performed. (-16-)
- Is the tape wound to the end? Insert a new Cassette. (-16-)
- Is the Camcorder power turned on? (-21-)
- Has condensation occurred? Wait until the Condensation Indication disappears. (-52-)

### **Other Recording**

#### **1: Auto Focus Function does not work.**

- Is Manual Focus Mode selected? If Auto Focus Mode is selected, focus is automatically adjusted. (-29-)

- There are some recording subjects and recording surroundings for which the Auto Focus Function does not operate correctly. In this case, use the Manual Focus Mode to adjust the focus. (-56-)

### **Editing**

#### **1: Audio dubbing cannot be performed.**

- Is the accidental erasure prevention slider on the Cassette open? If it is open (set to [SAVE]), recording cannot be performed. (-16-)
- Are you attempting to edit a tape portion that was recorded in LP Mode? LP Mode does not allow audio dubbing to operate. (-20-)

### **Indications**

#### **1: The Time Code becomes inaccurate.**

- The Time Code Indication counter may not be constant in the reverse direction in Slow Motion Playback Mode, but this is not a malfunction.

#### **2: The Remaining Tape Time Indication disappears.**

- When you record still pictures in Photoshot Mode, the Remaining Tape Time Indication may disappear temporarily. However, it reappears when recording normally.

#### **3: The Remaining Tape Time Indication does not match the actual remaining tape time.**

- If scenes of less than 15 seconds are continuously recorded, the remaining tape time cannot be displayed correctly.
- In some cases, the Remaining Tape Time Indication may show remaining tape time that is 2 to 3 minutes shorter than the actual remaining tape time.

### **Playback (Pictures)**

#### **1: Pictures cannot be played back even when the [▶] Button is pressed.**

- Is the Mode Dial set to Playback Mode? If not, the playback function cannot be used. (-32-)

#### **2: Mosaic-pattern noise appears on images during Cue, Review or Slow Motion Playback.**

- This phenomenon is characteristic of digital video systems. It is not a malfunction.

#### **3: Although the Camcorder is correctly connected to a TV, playback images cannot be seen.**

- Have you selected "Video Input" on the TV? Please read the operating instructions of your TV and select the channel that matches the input sockets used for the connection.
- Depending on your TV, nothing may be shown even if you correctly connect the Camcorder with your TV. In this case, set [AV JACK] on the [INITIAL] Sub-Menu to [OUT].

**4: Playback picture is not clear.**

- Are the heads of the Camcorder dirty? If the heads are dirty, playback image cannot be clear. (-53-)

**5: Playing back or recording do not function, the screen has frozen or the indication has disappeared.**

- Turn the Camcorder off. If the Camcorder is not turned off after operating the [OFF/ON] switch, press the [RESET] Button (-11-) first. And detach the Battery or AC Adaptor and then reattach it.

**Playback (Sound)****1: Sound is not played back from the built-in speaker of the Camcorder or the headphones.**

- Is the volume too low? During playback, push the [W/T] Lever to display the [VOLUME] Indication and adjust the volume. (-32-)

**2: Different sounds are reproduced at the same time.**

- [12bit AUDIO] on the [PLAYBACK] Sub-Menu of the [TAPE PLAYBACK MENU] has been set to [MIX]. As a result, the original sound and sound that was recorded by audio dubbing are played back together. It is possible to reproduce the sounds separately. (-37-)

**3: The original sound was erased when audio dubbing was performed.**

- If you perform audio dubbing on a recording made in [16bit] Mode, the original sound will be erased. If you wish to preserve the original sound, be sure to select [12bit] Mode at the time of recording.

**4: Sounds cannot be played back.**

- Although a Cassette with no audio dubbing is being played, is [12bit AUDIO] on the [PLAYBACK] Sub-Menu of the [TAPE PLAYBACK MENU] set to [ST2]? To play back a Cassette with no audio dubbing, [12bit AUDIO] must be set to [ST1]. (-37-)
- Is the Variable Speed Search Function working? Press the [▶] Button to cancel the Variable Speed Search Function. (-33-)

**Others****1: The Magic Wire Remote Control with Narration Mic (optional) does not operate correctly.**

- If it is not plugged in tightly, it will not operate correctly.

**2: The Camcorder clatters when shaking it.**

- It is a sound of the lens moving, not a malfunction.

**Explanation of Terms****■ Digital Video System**

In a digital video system, images and sounds are converted into digital signals and recorded on a tape. This complete digital recording is capable of recording and playback with minimal image and sound deterioration.

In addition, it automatically records data, such as Time Code and Date/Time, as digital signals.

**Compatibility with S-VHS or VHS Cassettes**

Because this Camcorder employs a digital system for recording image and sound data, it is not compatible with conventional S-VHS or VHS video equipment that employs an analog recording system.

The size and shape of the Cassettes are also different.

**Compatibility with Output Signals**

Because AV signal output from the AV signal output socket is analog (the same as conventional video systems), this Camcorder can be connected with S-VHS or VHS video or a TV for playback.

**■ Focus****Auto Focus Adjustment**

The Auto Focus System automatically moves forward and backward the focusing lens inside the Camcorder to bring the subject into focus so that the subject can be seen clearly.

However, the Auto Focus System does not function properly for the following subjects or under the following recording conditions.

**Please use the Manual Focus Mode instead.**

- 1) Recording a subject whose one end is located closer to the Camcorder and the other end farther away from it**
  - Because Auto Focus makes adjustments at the center of an image, it may be impossible to focus on a subject that is located in both foreground and background.
- 2) Recording a subject behind dirty or dusty glass**
  - Because the focus is on the dirty glass, the subject behind the glass will not be focused.
- 3) Recording a subject in dark surroundings**
  - Because the light information that comes through the lens decreases considerably, the Camcorder cannot focus correctly.
- 4) Recording a subject that is surrounded by objects with glossy surfaces or by highly reflective objects**
  - Because the Camcorder focuses on the objects with glossy surfaces or on highly reflective objects, the subject may become blurry.



**5) Recording a fast-moving subject**

- Because the focus lens-inside moves mechanically, it cannot keep up with the fast-moving subject.

**6) Recording a subject with little contrast**

- Because the Camcorder achieves focus based upon the vertical lines of an image, a subject with little contrast, such as a white wall, may become blurry.

**Time Code**

Time Code signals are data that indicate time measured in hours, minutes, seconds, and frames (30 frames per second). If this data is included in a recording, an address is assigned to each image on the tape.

- The Time Code is automatically recorded as a part of the sub-code at each recording.
- When a new (previously unrecorded) Cassette is inserted, the Time Code automatically starts from zero. If a recorded Cassette is inserted, the Time Code picks up from the point where the last scene was recorded. (In this case, when the Cassette is inserted, the zero display [0h00m00s00f] may appear, but the Time Code starts from the previous value.)
- The Time Code cannot be reset to zero.
- Unless the Time Code is continuously recorded from the beginning of a tape, accurate editing may not be possible. To ensure that the Time Code will be recorded with no breaks, we recommend the use of the Blank Search Function (-22-) before recording a new scene.

**Memory Stop Function**

The Memory Stop Function is useful for the following operations.

**Rewinding or fast-forwarding a tape to a desired position**

- 1 Set [DISPLAY] >> [C.DISPLAY] >> [MEMORY].**
- 2 Reset the Tape Counter to zero at the tape position from which you want to play it back later. (-12-, -19-)**
- 3 Start playback or recording.**
- 4 After playback or recording has finished: Set the Camcorder to Tape Playback Mode.**
- 5 Rewind the tape.**
  - The tape automatically stops approximately at the position where the counter was set to zero.

**Stopping editing automatically during audio dubbing**

- 1 Set [DISPLAY] >> [C.DISPLAY] >> [MEMORY].**
- 2 Reset the Tape Counter to zero at the position where you want to stop editing.**
- 3 Play back the still picture where you want to start audio dubbing.**

**4 Start audio dubbing. (-37-)**

- Audio dubbing automatically stops at the position where the counter was set to zero.

## Specifications

### Digital Video Camera

Information for your safety

#### Power Source:

DC 7.9/7.2 V

#### Power Consumption:

Recording

5.0 W

#### Recording Format:

Mini DV (Consumer-use Digital Video SD Format)

#### Tape Used:

6.35 mm digital video tape

#### Recording/Playback Time:

SP: 80 min.; LP: 120 min. (with DVM80)

#### Video

#### Recording System:

Digital Component

#### Television System:

EIA Standard: 525 lines, 60 fields NTSC color signal

#### Audio

#### Recording System:

PCM Digital Recording

16 bit (48 kHz/2ch), 12 bit (32 kHz/4ch)

#### Image Sensor:

1/6-inch CCD Image Sensor

#### Lens:

Auto Iris, F1.8, Focal Length; 2.3–23 mm, Macro

(Full Range AF)

#### Filter Diameter:

27 mm

#### Zoom:

10:1 Power Zoom

#### Monitor:

2.5-inch LCD

#### Viewfinder:

Color Electronic Viewfinder

#### Microphone:

Stereo

#### Speaker:

1 round speaker 20 mm

#### Standard Illumination:

1,400 lx

#### Minimum Required Illumination:

1 lx (MagicPix Mode)

#### Video Output Level:

1.0 Vp-p, 75 ohm

#### S-Video Output Level:

Y Output: 1.0 Vp-p, 75 ohm

C Output: 0.286 Vp-p, 75 ohm

#### Audio Output Level (Line):

316 mV, 600 ohm

#### Mic Input:

Mic sensitivity -50 dB (0 dB=1 V/Pa, 1 kHz)

(Stereo mini jack)

#### USB:

USB 2.0 compliant (max. 12 Mbps)

#### Digital Interface:

DV Input/Output Terminal (IEEE1394, 4-pin)

#### Dimensions:

Approx. 2.48 (W)×3.07 (H)×3.9 (D) inch

Approx. 63 (W)×78 (H)×99 (D) mm

#### Weight:

Approx. 0.8 lbs. (365 g)

(without Battery and DV cassette)

#### Operating Temperature:

32°F–104°F (0°C–40°C)

#### Operating Humidity:

10%–80%

#### AC Adaptor

Information for your safety

#### Power Source:

AC 110–240 V, 50/60 Hz

#### Power Consumption:

19 W

#### DC Output:

DC 7.9 V, 1.4 A (Camcorder Operation)

DC 8.4 V, 0.65 A (Battery Charging)

#### Dimensions:

2.40 (W)×1.26 (H)×3.58 (D) inch

61 (W)×32 (H)×91 (D) mm











#### Weight:

Approx. 0.24 lbs. (110 g)

Weight and dimensions are approximate values.

Specifications may change without prior notice.

**Camcorder Accessory System**

| Accessory#   | Figure  | Description                                   |
|--------------|---|---|
| PV-DAC13     |    | AC Adaptor with AC Cable and DC Cable         |
| *CGA-DU07    |    | 680mAh/Rechargeable Lithium Ion Battery Pack  |
| *CGA-DU14    |    | 1360mAh/Rechargeable Lithium Ion Battery Pack |
| *CGA-DU21    |    | 2040mAh/Rechargeable Lithium Ion Battery Pack |
| PV-DDC9      |    | DV Interface Cable (i.LINK) (4-pin to 4-pin)  |
| PV-DRC10     |    | IR Remote Control                             |
| N2QCBD000030 |    | Magic Wire Remote Control with Narration Mic  |
| LSFT0577     |    | DV STUDIO 3.1E-SE                             |
| K1HA05CD0005 |    | USB Cable                                     |
| PV-H150      |   | Carrying Case                                 |
| PV-HB002     |  | Carrying Case                                 |

\*Please refer to page -14-, concerning the battery charging time and available recording time.

**\*NOTE: Accessories and/or model numbers may vary by country. Please consult your local dealer.**

**Camcorder Accessory Order Form**

Please photocopy this form when placing an order.

1. Camcorder Model # \_\_\_\_\_

2. Items Ordered

| Accessory #                  | Description | Price Each | Quantity | Total Price |
|------------------------------|-------------|------------|----------|-------------|
|                              |             |            |          |             |
|                              |             |            |          |             |
|                              |             |            |          |             |
| Subtotal                     |             |            |          |             |
| Your State & Local Sales Tax |             |            |          |             |
| Shipping & Handling          |             |            |          | 6.95        |
| Total Enclosed               |             |            |          |             |

3. Method of payment (check one)

- Check of Money Order enclosed (NO C.O.D.SHIPMENTS)
- VISA                      Credit Card # \_\_\_\_\_
- MasterCard              Expiration Date \_\_\_\_\_
- Discover                    Customer Signature \_\_\_\_\_

Make Check or Money Order to: PANASONIC ACCESSORIES

(Please do not send cash)

4. Shipping information (UPS delivery requires complete street address)

Ship To:

Mr.

Mrs.

Ms.

First \_\_\_\_\_ Last \_\_\_\_\_

Phone#:

Day ( ) \_\_\_\_\_

Street Address \_\_\_\_\_

Night ( ) \_\_\_\_\_

City \_\_\_\_\_ State \_\_\_\_\_ Zip \_\_\_\_\_

TO OBTAIN ANY OF OUR CAMCORDER ACCESSORIES YOU CAN DO ANY OF  
THE FOLLOWING:  
VISIT YOUR LOCAL PANASONIC DEALER  
OR  
CALL PANASONIC'S ACCESSORY ORDER LINE AT 1-800-332-5368  
[6 AM-5 PM M-F, 6 AM-10:30 AM SAT, PACIFIC TIME]  
OR  
MAIL THIS ORDER TO: PANASONIC SERVICES COMPANY ACCESSORY ORDER OFFICE  
20421 84th Avenue South Kent, WA. 98032

---

***Request for Service Notice***

---

Please photocopy this form when making a request for service notice.

In the unlikely event this product needs service.

## **Request for Service Notice:**

- Please include your **proof of purchase**.  
(Failure to do so will delay your repair.)
  - To further speed your repair, please provide an explanation of what wrong with the unit and any symptom it is exhibiting.
- 
- 
- 

---

Mail this completed form and your Proof of Purchase along with your unit to:  
Panasonic Services Company  
1705 N. Randall Road  
Elgin, IL. 60123-7847  
Attn: Camcorder Repair

**Limited Warranty**

PANASONIC CONSUMER ELECTRONICS  
 COMPANY, DIVISION OF MATSUSHITA  
 ELECTRIC CORPORATION OF AMERICA  
 One Panasonic Way Secaucus, New Jersey 07094

PANASONIC SALES COMPANY, DIVISION OF MATSUSHITA  
 ELECTRIC OF PUERTO RICO, INC.,  
 AVE. 65 de Infantería, Km. 9.5 San Gabriel Industrial Park,  
 Carolina, Puerto Rico 00985

**Panasonic/Quasar Video Products  
 Limited Warranty**

**Limited Warranty Coverage**

If your product does not work properly because of a defect in materials or workmanship, Panasonic Consumer Electronics Company or Panasonic Sales Company (collectively referred to as "the warrantor") will, for the length of the period indicated on the chart below, which starts with the date of original purchase ("warranty period"), at its option either (a) repair your product with new or refurbished parts, or (b) replace it with a new or a refurbished product. The decision to repair or replace will be made by the warrantor.

| Product  | Parts   | Labor                                | Service  | Contact Number       |
|--|---|--------------------------------------|--|----------------------|
| Camcorder  | One (1) Year (except CCD Image Sensor)<br>CCD Image Sensor - 6 (Six) Months | Ninety (90) Days<br>Ninety (90) Days | Carry-In or Mail-In  | 1-800-211-PANA(7262) |
| DVD/VCR Deck,<br>A/V Mixer                                       | One (1) Year  | Ninety (90) Days                     | Carry-In or Mail-In  | 1-800-211-PANA(7262) |
| TV/VCR, TV/DVD,<br>TV/DVD/VCR<br>Combination                     | One (1) Year (except CRT)<br>CRT - Two (2) Years                            | Ninety (90) Days<br>Ninety (90) Days | Carry-In: 21"<br>CRT and Smaller<br>In-Home or Carry-In:<br>22" CRT and Larger | 1-800-211-PANA(7262) |
| TV/HDR<br>Combination  | One (1) Year (except CRT)<br>CRT - Two (2) Years                            | Ninety (90) Days<br>Ninety (90) Days | In-Home or Carry-In  | 1-888-843-9788       |
| Rechargeable<br>Batteries<br>(in exchange for<br>defective item) | Ten (10) Days   | Not Applicable                       | Carry-In or Mail-In  | 1-800-211-PANA(7262) |
| Tape<br>(in exchange for<br>defective item)                      | Five (5) Days   | Not Applicable                       | Carry-In or Mail-In  | 1-800-211-PANA(7262) |
| Memory Cards<br>(in exchange for<br>defective item)              | Ninety (90) Days  | Not Applicable                       | Carry-In or Mail-In  | 1-800-211-PANA(7262) |

During the "Labor" warranty period there will be no charge for labor. During the "Parts" warranty period, there will be no charge for parts. You must carry-in or mail-in your product or arrange for in-home service, as applicable, during the warranty period. If non-rechargeable batteries are included, they are not warranted. This warranty only applies to products purchased and serviced in the United States or Puerto Rico. This warranty is extended only to the original purchaser of a new product which was not sold "as is". A purchase receipt or other proof of the original purchase date is required for warranty service.

**Carry-In, Mail-in or In-Home Service**

For Carry-In, Mail-In or In-Home Service (as applicable) in the United States call toll free contact number listed above or visit Panasonic Web Site: <http://www.panasonic.com>

For assistance in Puerto Rico call Panasonic Sales Company (787)-750-4300 or fax (787)-768-2910.

In-Home service, if applicable, requires clear, complete and easy access to the product by the authorized servicer and does not include removal or re-installation of an installed product. It is possible that certain in-home repairs will not be completed in-home, but will require that the product, or parts of the product, be removed for shop diagnosis and/or repair and then returned.

**Limited Warranty Limits And Exclusions**

This warranty ONLY COVERS failures due to defects in materials or workmanship, and DOES NOT COVER normal wear and tear or cosmetic damage, nor does it cover markings or retained images on the picture tube resulting from viewing fixed images (including, among other things, letterbox pictures on standard 4:3 screen TV's, or non-expanded standard 4:3 pictures on wide screen TV's, or onscreen data in a stationary and fixed location). The warranty ALSO DOES NOT COVER damages which occurred in shipment, or failures which are caused by products not supplied by the warrantor, or failures which result from accidents, misuse, abuse, neglect, mishandling, misapplication, alteration, faulty installation, set-up adjustments, misadjustment of consumer controls, improper maintenance, power line surge, lightning damage, modification, or commercial use (such as in a hotel, office, restaurant, or other business), rental use of the product, service by anyone other than a Factory Servicenter or other Authorized Servicer, or damage that is attributable to acts of God.

**THERE ARE NO EXPRESS WARRANTIES EXCEPT AS LISTED UNDER "LIMITED WARRANTY COVERAGE". THE WARRANTOR IS NOT LIABLE FOR INCIDENTAL OR CONSEQUENTIAL DAMAGES RESULTING FROM THE USE OF THIS PRODUCT, OR ARISING OUT OF ANY BREACH OF THIS WARRANTY.**

(As examples, this excludes damages for lost time, cost of having someone remove or re-install an installed unit if applicable, or travel to and from the servicer, loss of media or images, data or other memory or recorded content. The items listed are not exclusive, but are for illustration only.)

**ALL EXPRESS AND IMPLIED WARRANTIES, INCLUDING THE WARRANTY OF MERCHANTABILITY, ARE LIMITED TO THE PERIOD OF THE LIMITED WARRANTY.**

Some states do not allow the exclusion or limitation of incidental or consequential damages, or limitations on how long an implied warranty lasts, so the exclusions may not apply to you. This warranty gives you specific legal rights and you may also have other rights which vary from state to state. If a problem with this product develops during or after the warranty period, you may contact your dealer or Servicenter. If the problem is not handled to your satisfaction, then write to the warrantor's Consumer Affairs Department at the addresses listed for the warrantor.

**PARTS AND SERVICE (INCLUDING COST OF AN IN-HOME SERVICE CALL, WHERE APPLICABLE) WHICH ARE NOT COVERED BY THIS LIMITED WARRANTY ARE YOUR RESPONSIBILITY.**

## Customer Services Directory

Obtain Product Information and Operating Assistance; locate your nearest Dealer or Servicenter; purchase Parts and Accessories; or make Customer Service and Literature requests by visiting our Web Site at:

<http://www.panasonic.com/support>

or, contact us via the web at:

<http://www.panasonic.com/contactinfo>

You may also contact us directly at:

1-800-211-PANA (7262),

Monday-Friday 9 am-9 pm; Saturday-Sunday 10 am-7 pm, EST

**For hearing or speech impaired TTY users, TTY : 1-877-833-8855**

### Accessory Purchases

Purchase Parts, Accessories and Instruction Books online for all Panasonic Products by visiting our Web Site at:

<http://www.pasc.panasonic.com>

or, send your request by E-mail to:

[npcparts@panasonic.com](mailto:npcparts@panasonic.com)

You may also contact us directly at:

1-800-332-5368 (Phone) 1-800-237-9080 (Fax Only) (Monday – Friday 9 am to 8 pm, EST.)

Panasonic Services Company

20421 84th Avenue South,

Kent, WA 98032

(We Accept Visa, MasterCard, Discover Card, American Express, and Personal Checks)

**For hearing or speech impaired TTY users, TTY : 1-866-605-1277**

### Product Repairs

#### Centralized Factory Servicenter

MAIL TO:

Panasonic Services Company

1705 N. Randall Road,

Elgin, IL 60123-7847

Attention: Camcorder Repair

Please carefully pack and ship, prepaid and insured, to the Elgin Centralized Factory Servicenter Customer's in Puerto Rico, please ship or carry in to location below ("Service in Puerto Rico").

#### Service in Puerto Rico

**Matsushita Electric of Puerto Rico, Inc. Panasonic Sales Company**

**Factory Servicenter:**

**Ave. 65 de Infantería, Km. 9.5, San Gabriel Industrial Park,**

**Carolina, Puerto Rico 00985**

**Phone (787)750-4300, Fax (787)768-2910**

As of October 2003

**Index**

- A**
- AC Adaptor ..... 14, 52
  - Audio Dubbing ..... 37
  - Auto Focus ..... 56
- B**
- Backlight Compensation ..... 25
  - Black & White Mode ..... 30
  - Blank Search ..... 22
- C**
- Camcorder Accessory Order Form ..... 60
  - Camcorder Accessory System ..... 59
  - Charging the Battery ..... 14
  - Cinema Mode ..... 27
  - Condensation ..... 52
  - Continuous Photoshot ..... 22
  - Cue Playback ..... 32
  - Customer Services Directory ..... 63
- D**
- Date/Time Indication ..... 47
  - Date/Time Setting ..... 20
  - Digital Effects ..... 30
  - Digital Still Picture ..... 22
  - Digital Zoom ..... 24
  - Dubbing ..... 37, 38
  - DV STUDIO 3.1E-SE ..... 43
- E**
- Erasure Prevention Slider ..... 16
- F**
- F Number ..... 29
  - Fade ..... 25
- I**
- Image Stabilizer Function ..... 24
  - Index Search ..... 34
  - Initializing the Modes ..... 47
  - Iris ..... 29
- L**
- LCD Monitor ..... 17, 54
  - Limited Warranty (USA) ..... 62
  - Low Light Mode ..... 27
- M**
- Macro Close-up ..... 24
  - Magic Wire Remote Control with Narration  
  Mic ..... 12
  - MagicPix Function ..... 26
  - Manual Focus ..... 29
  - Menu Screen ..... 18
  - Microphone ..... 24
  - Mirror Mode ..... 30
  - Mix Mode ..... 30
  - Mosaic Mode ..... 30
  - Multi-Picture Mode ..... 30
- N**
- Negative Mode ..... 30
- P**
- Photoshot ..... 22
  - Picture-in-Picture Mode ..... 31
  - Playback Digital Effects ..... 35
  - Playback Zoom ..... 34
  - Playing Back on Your TV ..... 36
  - Portrait Mode ..... 27
  - Program AE ..... 27
- Q**
- Quick Start ..... 23
- R**
- Recording Check ..... 21
  - Recording Speed ..... 20
  - Remaining Tape Time ..... 46
  - Remote Controller ..... 12
  - Repeat Playback ..... 50
  - Request for Service Notice ..... 61
  - Review Playback ..... 32
- S**
- Self-Recording ..... 23
  - Self-timer Recording ..... 23
  - Sepia Mode ..... 30
  - Shutter Speed ..... 29
  - Slim Mode ..... 30
  - Slow Motion Playback ..... 33
  - Soft Skin Function ..... 26
  - Solarisation Mode ..... 30
  - Sound Volume ..... 32
  - SP/LP Mode ..... 20
  - Sports Mode ..... 27
  - Spotlight Mode ..... 27
  - Still Advance Playback ..... 33
  - Stretch Mode ..... 30
  - Strobe Mode ..... 30
  - Surf & Snow Mode ..... 27
- T**
- Tele-Macro Function ..... 24
  - Time Code ..... 57
  - Trailing Effect Mode ..... 30
- U**
- USB Connection Kit ..... 39
- V**
- Variable Speed Search ..... 33
  - Video Head Clogging ..... 53
  - Viewfinder ..... 17, 54
- W**
- Web Camera ..... 40
  - White Balance ..... 27
  - Wind Noise Reduction ..... 26
  - Wipe Mode ..... 30
- Z**
- Zoom ..... 23
  - Zoom Microphone ..... 24



## Spanish Quick Use Guide/ Guía española para el uso rápido

### 1 Una la batería al adaptador de CA y cárguela.

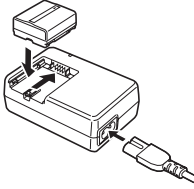

- Antes de usar, cargue completamente la batería.
- Dado que la batería no se cargará cuando el cable de entrada CC está conectado al adaptador de CA, desconéctelo.
- La [CHARGE] lámpara se enciende y comienza la carga.
- Cuando se apaga la luz [CHARGE], termina la carga.

### 2 Meta la batería cargada en la videocámara.

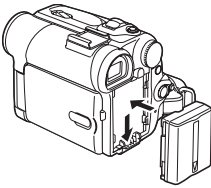

### Colocación del cassette

- 1 Desplace la palanca [OPEN/EJECT] **1** hacia delante y tire hacia abajo para abrir el compartimento del cassette.
- 2 Inserte el cassette.

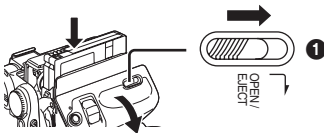

- 3 Cierre el soporte del cassette presionando la marca [PUSH] **2**.
- 4 Cierre la tapa del compartimento del cassette.

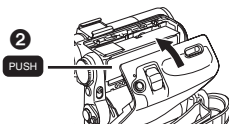

### Grabación en una cinta

- 1 Ponga el interruptor [OFF/ON] **1** en [ON].
  - La lámpara [POWER] **2** se enciende.

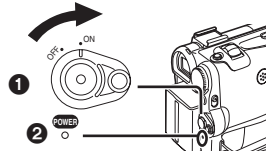

- 2 Ajuste el disco del modo al de la grabación de cinta.

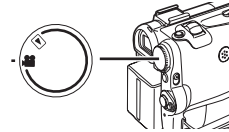

- 3 Oprima el botón de inicio/parada de la grabación.

- Comienza la grabación.

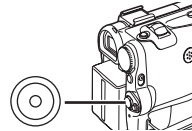

- 4 Oprima de nuevo el botón de inicio/parada de grabación para detener brevemente la grabación.

### Grabación de una imagen fija en una cinta (Photoshot)

- 1 Ajuste el disco del modo al de la grabación de cinta.

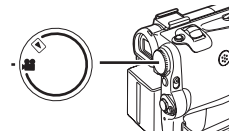

- 2 Oprima el botón [PHOTO SHOT].

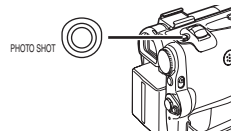

## Reproducción de una cinta

1 Ponga el interruptor [OFF/ON] ① en [ON].

- La lámpara [POWER] ② se enciende.

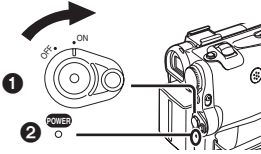

2 Ajuste el disco del modo al de la reproducción de cinta.

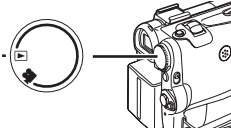

3 Oprima el botón [◀◀] para rebobinar la cinta.



4 Oprima el botón [▶] para comenzar la reproducción.

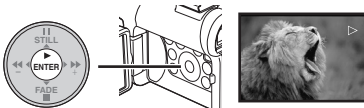

5 Oprima el botón [■] para parar la reproducción.





**Panasonic Consumer Electronics Company,  
Division of Matsushita Electric Corporation of America**

**Executive Office:**

One Panasonic Way, Secaucus, NJ 07094  
(201) 348-7000

**Panasonic Company East:** 6749 Baymeadow Drive, Glen Burnie, MD 21060

**Panasonic Company Central:** 1707 North Randall Road, Elgin, IL 60123

**Panasonic Company West:** 6550 Katella Avenue, Cypress, CA 90630

**Division of Matsushita Electric Corporation of America**

**Panasonic Sales Company (“PSC”)**

**Division of Matsushita Electric of Puerto Rico, Inc.**

San Gabriel Industrial Park, Ave. 65 de Infanteria, Km. 9.5, Carolina, PR 00985

